



THE EFFECTS OF WIND TURBINE FARMS ON ATC RADAR

AWC/WAD/72/665/TRIALS

10 MAY 05

OPEN REPORT

THE EFFECTS OF WIND TURBINE FARMS ON ATC RADAR

EXECUTIVE SUMMARY

1. The UK Government supports the introduction of wind turbine farms as part of its alternative energy strategy. However, Ministry of Defence (MoD) guidelines restrict planning consent for wind turbine farms within line of sight (LoS) from Primary Surveillance Radars and in close proximity to Royal Air Force (RAF) Airfields. The validity of these guidelines has been the subject of close scrutiny by the wind farm developers. Consequently, a trial was conducted by the Air Command and Control Operational Evaluation Unit (Air C2 OEU) in response to a tasking from Headquarters No 3 Group (HQ 3 Gp), to determine the effects of wind turbine farms on Air Traffic Control (ATC) Primary Surveillance Radars. Stage 1 of the Trial was a scoping exercise over the period 3-4 Nov 04, utilising the Watchman radar at RAF Valley and the Trysglwyn and Rhyd-y-Groes wind turbine farms. Stage 2, the start of the main trial, was conducted in the period 23-25 Nov 04 utilising the Llandinam (P&L) wind turbine farm in South Wales. A Watchman Radar was deployed to a privately owned site in Shropshire, slightly south of the National Air Traffic Services (NATS) Radar Site at Clee Hill. This deployment provided medium-range data from within the main beam of the radar. Stage 3 was conducted during the period 13-14 Dec 04, again utilising the P&L wind turbine farm but with the Watchman Radar on a soft-field site at Llanbister. This provided short-range data from within the auxiliary beam of the radar.
2. The aim of the Trial was to determine the effects of wind turbine farms on the ATC area and airfield primary surveillance radars. This was achieved by tasking scripted sorties with a variety of aircraft types to over-fly the subject wind turbine farms. The radar video display was assessed during the Trial and radar video output was captured for analysis.
3. Previous research had predicted a shadow region behind the wind turbines within which primary radar responses would be masked. The precise technical reason for this shadow remains unproven. This trial confirmed the presence of this effect for the Watchman. Throughout the Trial, clutter was displayed to the operator as a result of the motion of the wind turbines. **This displayed clutter was assessed as highly detrimental to the safe provision of Air Traffic Services (ATS).** Moreover, an ATC operator would be unable to differentiate between returns from the turbine blades and those from real aircraft. Therefore, for the purposes of achieving separation, the ATC operator would be obliged to treat turbine-induced returns as though they were aircraft. Finally, the Probability of Detection (PD) of aircraft by the Watchman Radar was considerably reduced when aircraft were overhead, or in close proximity to the wind turbines.

OPEN REPORT

THE EFFECTS OF WIND TURBINE FARMS ON ATC RADAR

INTRODUCTION

4. The UK Government supports the introduction of wind turbine farms as part of its alternative energy strategy. The existing MoD Guidelines restrict planning consent for wind turbine developments in the vicinity of primary surveillance radars and in close proximity to RAF Airfields. The validity of these guidelines has been the subject of close scrutiny by the wind farm developers. Consequently, HQ 3 Gp tasked the Air C2 OEU with determining the effects of wind turbine farms on the ATC area and airfield surveillance radars.

5. There is a growing body of evidence regarding the impact of wind turbine farms on radars and recent MoD trials have concentrated on Air Defence (AD) radars. Stage 1 of this latest trial was conducted as a scoping exercise over the period 3 – 4 Nov 04 and utilised the Trysglwyn and Rhyd-y-Groes wind turbine farms on Anglesey and the Watchman Radar at RAF Valley. Stage 1 was intended to gain an understanding of the nature of the interaction between the Watchman Radar and wind turbines within LoS. A Griffin HT1 aircraft provided a single specific sortie in support of Stage 1, while Hawk T Mk1A aircraft provided targets (tgts) of opportunity. Stage 2 of the Trial was conducted between 23 – 25 Nov 04. For Stage 2, a Watchman Radar was deployed to a privately owned site in Shropshire, slightly south of the NATS radar site at Clee Hill. This was in order to utilise the P&L wind turbine farm in South Wales as a source of potential interference. For Stage 3 the radar deployed to Llanbister during the period 13-14 Dec 04. Sorties in support of Stages 2 and 3 were flown by Hawk T Mk1A, Tucano T Mk1, Dominie T Mk1A and Gazelle AH Mk1 aircraft. Specialist support was provided by personnel from the Directorate of Engineering Interoperability and Information Services (DEI&IS), Defence Science and Technology Laboratory (Dstl) and relevant RAF units.

AIM

6. The aim of this Trial was to determine the effects of wind turbine farms on ATC area and airfield Primary Surveillance Radars.

TRIAL OBJECTIVES

7. The objectives of this Trial were to:
- a. Observe and determine the effect that wind turbine farms have on ATC area and airfield Primary Surveillance Radar performance with regard to:
 - (1) PD.
 - (2) Displayed effect.
 - b. Provide guidance on system set-up and observed displayed effects on the Watchman Radar.

ASSOCIATED TASKS

8. It was intended that the theoretical impact of wind turbine farms on the new generation of Precision Approach Radar (PAR) would also be considered during this Trial.

CONDUCT OF TRIAL

STAGE 1

9. Due to a lack of specialist knowledge within the Air Warfare Centre (AWC) or Dstl, regarding the effect of wind turbine farms on ATC surveillance radars, Stage 1 of the Trial was used as an information gathering exercise. This was to provide sufficient data to scope the design of Stages 2 and 3.

STAGE 2

10. Stage 2 was designed to ensure that sufficient medium range (57 km) data was gathered. This data would enable the AWC to provide advice to the sponsor on the impact of generic wind turbine farms on a representative, in-service ATC radar, the Watchman. The radar site was selected to ensure that the wind turbines were in the main beam of the radar¹.

STAGE 3

11. Stage 3 was designed to ensure that sufficient short range² data was gathered. The radar site was selected to ensure that the wind turbines were in the auxiliary beam of the radar³.

¹ Usually set to start 20-30 km from the radar head.

² The range was 8 km to the closest point on the wind farm and 12 km to the furthest point.

³ Usually employed for the first 20-30 km of coverage to overcome ground clutter.

EQUIPMENT UNDER TEST

12. The output of this Trial is intended to be applicable to all UK ATC radars in LoS of wind turbine farms. However, for the purposes of this Trial, the equipment under test for Stage 1 was the Watchman Radar installed at RAF Valley. For Stages 2 and 3 a deployable Watchman radar was utilised. The radars were set-up and calibrated iaw normal airfield radar installations. The wind farms evaluated during the Trial were:

- a. Stage 1 – Trysglwyn and Rhyd-y-Groes Wind Turbine Farms- Anglesey. The Trysglwyn wind turbine farm was commissioned in Jul 96 with 14 Bonus 400 turbines. Rhyd-y-Groes was commissioned in Dec 92 with 24 Bonus Mk III turbines. During the Trial the wind direction was WNW and 35 of the 38 turbines were rotating. The range from the radar to the wind turbine farm was 13 km.
- b. Stages 2 and 3– P&L Wind Turbine Farm - Wales. The P&L wind turbine farm was commissioned in Jan 1993 and comprises 103 Mitsubishi Type 300 turbines. The range from the radar to the wind turbine farm was 57 km. Stage 3 also utilised the P&L wind turbine farm but the Watchman radar was re-deployed to Llanbister. The radar to wind turbine farm range was 8-12 km. Turbine data collected during these Stages is detailed at Annex A.

TRIAL METHOD

13. It was expected that the impact from wind turbines on ATC radars would take 3 main forms and it was necessary to examine all 3 during the Trial. The effects are discussed in detail at Annex B but can be summarised as follows:

- a. Obscuration. Recent trials conducted by the Air C2 OEU had indicated obscuration of aircraft when over-flying wind turbines. For AD radars (3-dimensional (3-D) radars using Planar Phased Array antennae and multiple vertical beams) this obscuration was believed to be a result of clutter-processing techniques. A two-dimensional (2-D) radar, such as the Watchman, was expected to be more vulnerable to obscuration as it employs a single vertical beam⁴.
- b. Displayed Clutter. It was anticipated that the rotating turbine blades would induce a Doppler Shift on the radar returns and allow them to pass through the Moving Tgt Indicator (MTI) filters of the Watchman Radar processors. This would result in the display of unwanted returns (clutter or false alarms). Previous ATC trials had regarded clutter resulting from wind turbines as a key issue. This was particularly pertinent for the ATC community. They are obliged to pay due heed to clutter returns in close proximity to aircraft under their control and would have to assume that such returns were other aircraft in confliction. Moreover, the presence of a large number of clutter returns would mask any return from real aircraft. Obscuration can be regarded as a sub-set of clutter effects.
- c. Shadow. The presence of a large physical obstruction (with a large resultant Radar Cross Section (RCS)) in the path of the radar beam is known to result in a shadow

⁴ Notwithstanding the relationship between the short-range auxiliary beam and the medium-range main beam.

region behind the object. However, the radar beam rapidly reforms behind wind turbines due to diffraction, limiting the range of the shadow. The extended depth of shadow regions observed during previous trials is believed to be linked to how individual radar systems process clutter⁵. It was expected that during this Trial there would be a region immediately behind the wind turbines within which the PD of an aircraft was significantly reduced. Previous experience suggested that this region would be 2-3 kms deep.

14. Stage 1 Sorties. The aircraft utilised for Stage 1 were selected from aircraft types available at RAF Valley. The majority of observations were made against tgts of opportunity on an ad hoc basis during normal flying operations for the Station. This was sufficient for Stage 1 as previous research had indicated that Valley ATC was experiencing interference from wind turbines during routine operations. The RAF Valley Search and Rescue Training Unit provided a Griffin HT1 sortie in direct support of the Trial. This aircraft flew a flight profile of 3 runs, tangential to the radar, with one run directly over the wind farm.

15. Stage 2 and 3 Sorties. Stages 2 and 3 were the major stages of this Trial. They were designed to ensure sufficient data was gathered at medium and short range, to enable the AWC to provide advice to the sponsor on the impact of wind turbines on current ATC radar. Hawk T Mk1A, Dominie T Mk1A, Tucano T Mk1 and Gazelle AH Mk1 aircraft were tasked in support of these Stages. Flight Profiles are at Annexes C and D.

16. Data Recording. The effect of clutter resulting from a wind turbine farm could be assessed visually at the operator's video output. Integral Watchman Radar recording equipment was used to support data capture for later analysis. Watchman data is not plot extracted; therefore, precise, digital plot position information could not be collected.

TRIAL CONSTRAINTS

17. The following constraints applied to this Trial:

a. Due to the nature of this Trial it was necessary to observe a wind turbine farm in LoS of an ATC radar. The MoD routinely objects to significant wind turbine farm developments in close proximity to airfield radars. Existing developments within LoS of airfield radars are generally small, in terms of both numbers of turbines deployed and physical characteristics of those turbines. Therefore, it was necessary to use a deployable ATC radar for the Trial in order to examine the effect of a larger wind turbine farm on an airfield radar. The deployment site had to be suitable for the Watchman Radar⁶ and within LoS of a suitable wind turbine farm.

b. A Secondary Surveillance Radar (SSR) antenna was not integral to the Watchman system deployed in support of this Trial and no stand-alone system was available. Therefore, no SSR data was collected during this Trial. Lack of SSR complicates the analysis process but does not significantly affect the result of the Trial. No impact on SSR had been observed during the previous Air C2 OEU trial⁷.

⁵ General background noise and false alarms.

⁶ For physical deployment and clearance to radiate both primary radar and UHF ground to air communications.

⁷ Effect of wind turbines on AD Radar.

c. An upper height restriction of 24 000 ft was imposed on the Trial due to the proximity of the Welsh Military Training Area boundary. As the Watchman is a 2-D radar using a conventional single vertical beam it was anticipated that a height range of surface to 24 000 ft would be more than sufficient to obtain the necessary data.

TRIAL RESULTS

18. Stage 1. The purpose of Stage 1 was to raise core knowledge within the Air C2 OEU of how wind turbines interacted with the Watchman Radar. Sufficient observations were made to ensure that the sortie profiles for Stages 2 and 3 were appropriate. The observed effect on the controller's display when Hawk T Mk 1A aircraft approached or over-flew the wind turbine farm was a reduction in the signal strength, or complete loss of the expected response on the display. No effect on PD was observed during over-flight by the Griffin HT1. SSR was available throughout Stage 1 but there was no observed effect due to the wind turbines. No specific conclusions were drawn as a result of this Stage; however, the observations were used to inform planning for Stages 2 and 3.

19. Displayed Clutter. Clutter can prove misleading, inducing the operator to treat the clutter as though it were an aircraft. It can also affect the overall ambient noise level for the radar and raise the processing threshold in those range/azimuth cells where it is present. It was anticipated that the rotating blades of a wind turbine would induce a Doppler Shift on the radar reflections and thus allow them to pass through the MTI filters of the Watchman Radar, producing displayed clutter. This effect was observed during this Trial, as shown at Figure 1.

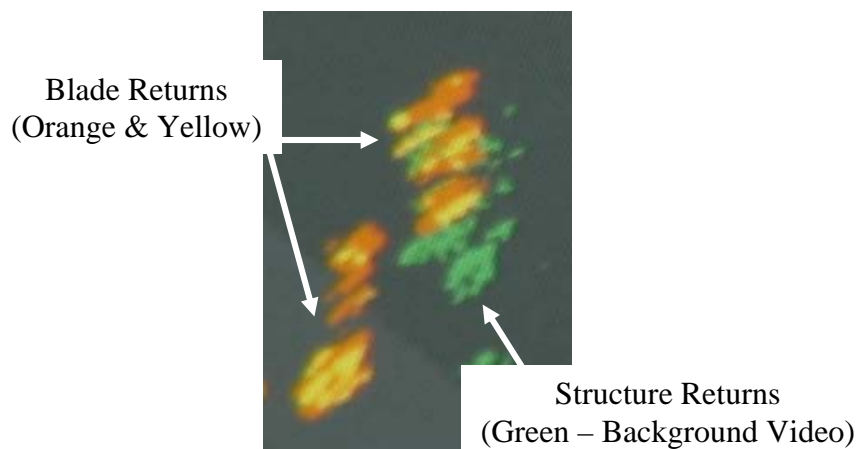

Figure 1 - Plots Displayed due to Doppler Shift from Blades.

The ambient noise level was also raised as a result of the returns from the wind turbine farm. During the Trial it was noted that the amplitude of the radar returns from the rotating turbine blades were 20-25 dBi over the ambient noise level during the Stage 2 deployment (57 km turbine to radar range). When the turbines were turning, their tip speed, approximately 75^8 ms^{-1} , was considerably greater than the speed of a slow moving aircraft. Therefore, turbine tips would always break through the MTI filters of a radar and result in display obscuration through on-screen clutter⁹. Displayed clutter returns are particularly pertinent for ATC. This is because controllers are obliged to react to clutter returns, in close proximity to aircraft under their control,

⁸ Equates to approximately 270 kmh^{-1} .

⁹ Watchman Radar MTI minimum speed is approximately 10 ms^{-1} .

and they would have to assume that such returns were other aircraft in confliction. The presence of a large number of clutter returns would mask any return from real aircraft, regardless of whether the actual aircraft return was obscured. In either instance, displayed clutter as a result of wind turbines has a significant impact on ATC. This problem is discussed further at Annex B. It is unreasonable to expect an aircraft on approach or manoeuvring in the vicinity of an active airfield to take avoiding actions on a false return caused by the wind turbines, particularly if that aircraft is operating in Instrument Meteorological Conditions (IMC). Therefore, due to the problem of displayed clutter, **it is recommended that planning applications for wind turbine farm developments be subject to scrutiny when in LoS of an airfield primary radar, regardless of range but in particular within 30nm of the radar head.**

20. Obscuration. Obscuration is a sub-set of clutter. For the purposes of this report, the word obscuration refers specifically to conditions leading to the loss of sensitivity in detection to such an extent that the aircraft returns are completely lost. This does not include the specific situation where an aircraft return is present on the screen but indistinguishable from other returns¹⁰. The extent to which the wind turbine structure¹¹ produced clutter and thus raised the ambient noise level was not anticipated prior to the Trial. The lack of Doppler Shift on radar returns from the structure allows the MTI circuitry to filter the returns and prevent them from being displayed to the operator. However, their effect on the ambient noise level remains unfiltered. The noise from the turbine structure was of the same magnitude whether or not the turbines were turning. The only key difference was that the turning blades allowed returns to pass the MTI filters and be displayed on screen instead of being held in background video. The radar was operated with a variety of channel filter selections throughout the Trial (a range of representative outputs are at Annexes E and F). It was consistently observed that the normal radar channel was the most susceptible to obscuration attributable to the wind turbine farm. This observation was in line with theoretical predictions. The effect of returns from wind turbines on the ambient noise level can be seen in Figures 2 and 3.

¹⁰ That being an extreme example of displayed clutter.

¹¹ Mast, gondola and non-rotating blades.

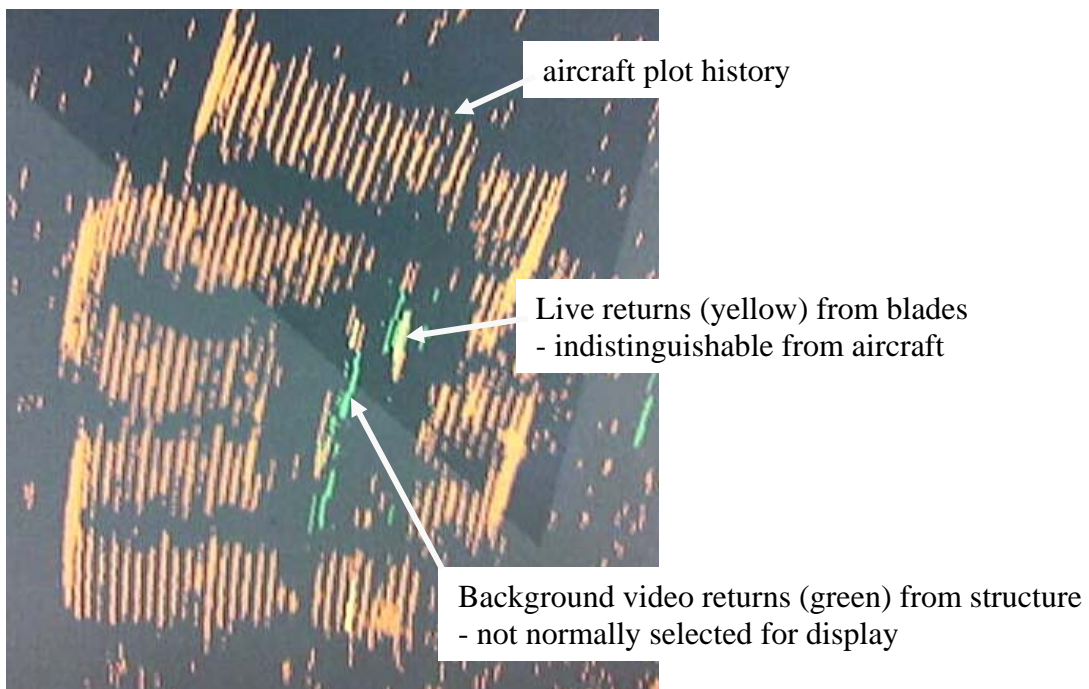

Figure 2 - Obscuration over P&L wind turbine farm due to raised ambient noise level.
(Normal radar channel only)

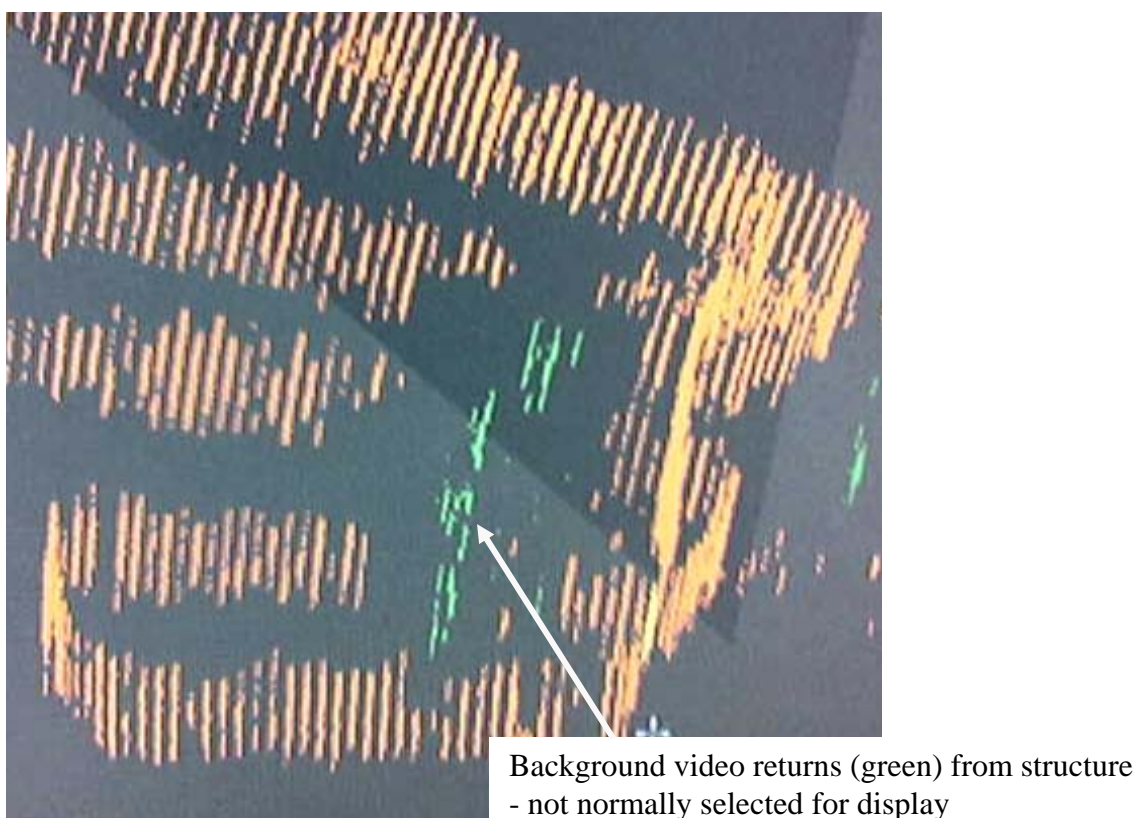

Figure 3 – Obscuration over P&L wind turbine farm with no turbines turning.
(Normal radar channel only)

Overall, the presence of any object with a massive RCS within LoS of a radar will degrade that radar's operational performance. The P&L wind turbine farm has an RCS estimated at 100^{12} m^2 , this figure could be as high as $10\,000 - 100\,000^{13} \text{ m}^2$ for some of the proposed larger wind turbines. The turbines significantly raised the ambient noise level and thus raised the processor thresholds within the radar processing chain whether or not they were turning. Loss of sensitivity including complete loss of detection was the result. The processed video displayed to an ATC operator allows the controller to apply experience and judgement in decoding background clutter from aircraft. Figure 4 shows how the structure of the wind turbine¹⁴ reduced the sensitivity of the radar by raising the ambient noise level. The exploded section, below right, shows a marked reduction in strength of return from the Dominie T Mk1A overflying the turbines. A controller could see that these returns still belong to the same aircraft.

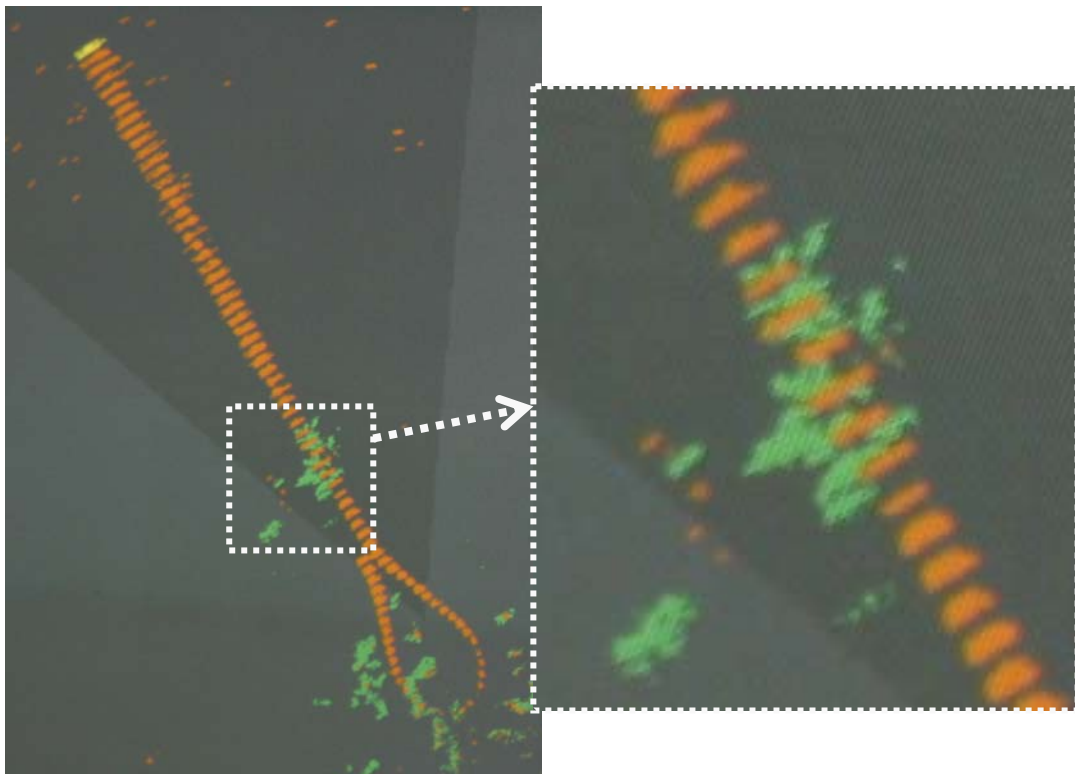

Figure 4 - Dominie at 4000 ft AMSL (all Channels Enabled) Overflying Turbines

¹² 20 dBm².

¹³ 40-50 dBm².

¹⁴ No blades turning.

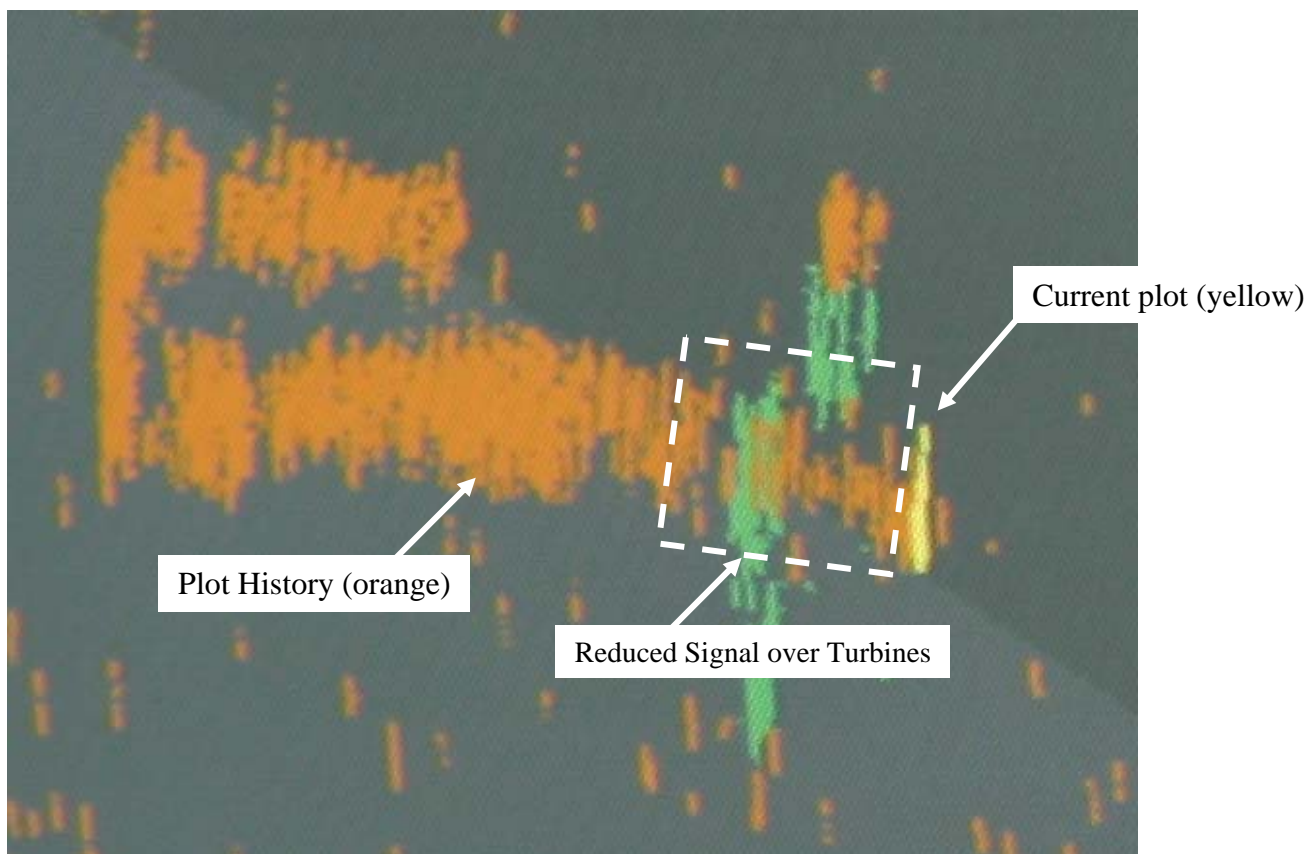

Figure 5 - Gazelle at 2000 ft AMSL with all Channels Enabled

In Figure 5 this effect is more pronounced and it is more difficult to distinguish the aircraft returns overhead the wind turbines. Figures 4 and 5 also demonstrate the advantages of using all 3 radar channels when attempting to detect aircraft flying over wind turbine farms. There was a marked decrease in the incidence of complete obscuration when all 3 channels were selected. In extreme situations a sufficiently intelligent plot extractor may be able to outperform an operator in distinguishing aircraft from clutter. This concept lies at the heart of proposals by companies such as AMS¹⁵ and the Sensis Corporation. These systems offer a potential solution to this problem. However, the performance of plot extracted Watchman variants would require rigorous testing in a realistic ATC environment, both with and without interference from wind turbines, before further comment could be made on their viability. As a controller could not be certain that there were unknown aircraft obscured by the wind turbines he would be obliged to take standard lateral separation against the entire wind turbine farm. Therefore, due to the obscuration of aircraft returns in the vicinity of wind turbines, **it is recommended that:**

- a. **ATS be limited within 5 nm¹⁶ of the boundary of a wind turbine farm.**
- b. **ATC personnel be advised to select all 3 Watchman channels when operating within 5 nm of a wind turbine farm.**

¹⁵ With the Advanced Digital Tracker (ADT).

¹⁶ Standard mandatory lateral separation for ATS is 5 nm (3 nm only when specifically authorised).

c. Further investigation be carried out to test the viability of plot extractor-based solutions to the interference effects of wind turbines in ATC environments.

21. Shadow. The presence of a large physical obstruction¹⁷ in the path of the radar beam had previously resulted in a shadow region behind the object. The shadow region extended beyond the range within which diffraction would be expected to reform the beam. This was believed to be related to the process by which individual radar systems process radar clutter (both general background noise and false alarms). This was observed during this Trial but occurred both behind and in front of the turbines, as shown at Figures 2 and 3. The loss of detection in front of the turbines, relative to the radar, was not the result of conventional shadowing as would be experienced when an object blocks a light beam. There are several possible explanations for this effect:

a. It is believed to result from the methods employed within the radar processing system to deal with clutter by raising the noise level in effected cells in the vicinity of the turbines. The basic compressed pulse length for the Watchman is 0.4 μ s, giving a 60 m range cell. Clutter in each range cell is assessed sweep by sweep and used to inform a clutter map using a process of alpha smoothing (1/8 of current clutter amplitude plus 7/8 of previous sweep clutter amplitude). The sliding window of range cells over which this process occurs has a composite range of approximately 0.5 km. Therefore, this process does not serve to fully explain the 2-3 km shadow¹⁸ that was observed either side of the wind turbines.

b. The uncompressed pulse length for the Watchman is 20 μ s, giving a 3 km uncompressed range cell. If processor limiting occurred in the radar processing prior to pulse compression, an effect would be observed over the range of the uncompressed 3 km pulse. However, whilst this range is superficially similar to the observed shadow, it is not believed to be a causal relationship¹⁹.

It is recommended that ATC personnel be made aware that aircraft returns are as likely to fade in front of a wind turbine as behind it (relative to the position of the Watchman radar).

22. SSR. SSR was not available and no assessment was made of the impact of wind turbines on SSR performance. Previous trials had not indicated any interference with SSR in the vicinity of wind turbines.

¹⁷ With a large resultant RCS.

¹⁸ Relative to the radar.

¹⁹ Based on extensive technical discussion with AMS (the manufacturer of the Watchman) including the original system designer. A return of 40-50 dB would have been required to put the pre-compression circuitry into limit.

TRIAL OBJECTIVES SATISFIED

OBJECTIVE 1. OBSERVE AND DETERMINE THE EFFECT THAT WIND TURBINE FARMS HAVE ON ATC AREA AND AIRFIELD PRIMARY SURVEILLANCE RADAR PERFORMANCE WITH REGARD TO PD AND DISPLAYED EFFECT.

23. Objective 1 provided the following:

a. PD. The images at Annexes E and F indicate that the PD for the Watchman was reduced overhead and in the immediate vicinity of wind turbines, whether or not the turbines were turning. Data analysis for area radars was dependant on data being supplied by NATS, who are the operators of area radars used by RAF ATC personnel, this data has not yet been provided. OBJECTIVE PARTIALLY SATISFIED

b. Displayed Effect. With the turbines in motion it was not possible to distinguish between the returns from a turbine blade and those from a real aircraft. This problem is shown in the images at Annexes E and F. Data analysis for area radars was dependent on data being supplied by NATS this data has not yet been provided. OBJECTIVE PARTIALLY SATISFIED

OBJECTIVE 2. PROVIDE OPERATOR GUIDANCE ON SYSTEM SET-UP AND OBSERVED DISPLAYED EFFECTS ON THE WATCHMAN RADAR.

24. Due to the safety-critical nature of ATC operations, the set-up procedures for Watchman Radar are clearly defined and tightly controlled. The Watchman radar in use for the Trial was set-up and calibrated as per a new airfield installation. In this configuration, the displayed effects were shown to interfere significantly with ATC operations. To alter the set-up to remove the effect of the wind turbines would require the processor thresholds to be raised by approximately 25 dB²⁰, rendering the radar unusable for its primary role. It is unlikely that there is a valid set-up option to mitigate the effects of a wind turbine farm in LoS of a Watchman radar being used for ATC. OBJECTIVE FULLY SATISFIED

ADDITIONAL OBSERVATION

25. Further analysis of the observed effects for a Watchman Radar in LoS of wind turbines, and possible solutions, is at Annex B.

26. The PAR system, recently installed at the majority of RAF airfields, was being modified by the manufacturers during this Trial. There was no benefit in conducting flight trials against the equipment prior to acceptance by the RAF. Therefore, PAR was not specifically tested during this Trial but remains a safety critical radar facility in routine use at MoD airfields. Air C2 OEU trials on both passive phased array AD radars and conventional reflector ATC radars have shown there to be an impact from wind turbines within LoS. This effect is believed to result from the large RCS of wind turbines raising the ambient noise level within specific radar clutter cells. The latest generation of PAR equipment installed at MoD airfields uses 2 active phased array antennae to provide 3-D positional information. These radars, therefore, have more in common with AD radars than conventional ATC airfield radars. The 115 element array used

²⁰ More for larger wind turbines.

to obtain elevation data should allow much greater control over the shape of the elevation beam than is possible with passive phased array AD radars. However, there is no evidence to suggest that the system has been designed with the intention of steering transmitter and receiver nulls in the elevation beam over potential sources of massive radar noise, such as wind turbine farms. In the absence of firm evidence, and given the safety critical nature of the PAR task, it would be prudent to assume that PAR will be subject to significant interference effects from wind turbines. Further investigation is required if the impact on PAR is to be fully understood. The maximum range for a PAR is 20nm and it would be necessary to take separation of up to 5nm laterally against unknown radar returns. Therefore, **it is recommended that:**

- a. For airfields where PAR is installed or likely to be installed, planning applications for wind turbine farm developments be subject to scrutiny within a cone of 25 degrees either side (complete arc of 50 degrees) of the runway centre-line to a range of 25nm.**
- b. A further trial be conducted to ascertain the vulnerability of the in-service PAR system to interference from wind turbines.**

EXTERNAL REVIEW

27. At the request of the sponsor, the contents of this report have been subject to peer review by the DEI&IS personnel who participated in Stages 2 and 3 of the Trial. They support the views expressed herein.

CONCLUSIONS

28. The presence of a wind turbine farm in LoS of a Watchman Radar had a significant impact on its ability to support ATC. This took 2 main forms, obscuration and displayed clutter. These were a result of the strong radar reflections received from high RCS moving tgts, like wind turbines. Due to the nature of the ATC task, it will always be necessary for controllers to honour the presence of a displayed radar return on their screen and treat it as though it was a real aircraft. Displayed clutter is a significant problem. Aircraft manoeuvring in the proximity of an airfield will often operate in IMC and rely on ATC for safe separation from conflicting aircraft. It is highly undesirable for aircraft on approach (particularly PAR, SRA or in the radar circuit) to be required to manoeuvre laterally to avoid other unknown radar contacts, particularly those generated by wind turbines. Flying over or in close proximity to a wind turbine can significantly hamper the ability of an ATC operator to maintain the identity of his own aircraft and is also unacceptable in the context of the safe provision of ATS. Overall, the presence of a wind turbine farm is not compatible with ATC operations in the vicinity of an airfield. A lateral separation of 5 nm should be maintained between wind turbine farms and areas where critical ATC operations take place.

RECOMMENDATIONS

MAJOR RECOMMENDATIONS

29. It is recommended that:

- a. Planning applications for wind turbine farm developments be subject to scrutiny when in LoS of an airfield primary radar, regardless of range but in particular within 30nm of the radar head. (Paragraph 19)
- b. ATS be limited within 5 nm of the boundary of a wind turbine farm. (Paragraph 20a)
- c. ATC personnel be advised to select all 3 Watchman channels when operating within 5 nm of a wind turbine farm. (Paragraph 20b)
- d. Further investigation be carried out to test the viability of plot extractor-based solutions to the interference effects of wind turbines in ATC environments. (Paragraph 20c)
- e. ATC personnel be made aware that aircraft returns are as likely to fade in front of a wind turbine as well as behind it (relative to the position of the Watchman radar). (Paragraph 21)
- f. For airfields where PAR is installed or likely to be installed, planning applications for wind turbine farm developments be subject to scrutiny within a cone of 25 degrees either side (complete arc of 50 degrees) of the runway centre-line to a range of 25nm. (Paragraph 26a)
- g. A further trial be conducted to ascertain the vulnerability of the in-service PAR system to interference from wind turbines. (Paragraph 26b)

<Original signed>

D M WEBSTER
Squadron Leader
Officer Commanding
Static Ground Systems Operational Evaluation Squadron
Air C2 OEU

10 May 05

Annexes:

- A. Windfarm Data During this Trial – Stages 2 And 3.
- B. Impact Of Wind Turbine Farms On ATC Radar – Further Analysis And Proposed Solutions.
- C. Sortie Profiles – Stage 2.
- D. Sortie Profiles – Stage 3.
- E. Watchman Display Output During this Trial Stage 2.
- F. Watchman Display Output During this Trial Stage 3.

ANNEX A TO
AWC/WAD/72/665/TRIALS
DATED 10 MAY 05

WINDFARM DATA DURING TRIAL – STAGES 2 AND 3

1. Data was collected on activity levels for the wind turbine farm during Stages 2 and 3 of this Trial. The key data was as follows:

Date	Time (local)	Turbines Operating	Wind Direction	Wind Speed (ms⁻¹)	Weather
Stage 2					
23 Nov 04	0930	0	Calm	N/A	overcast
	0955	0	Calm	N/A	overcast
	1115	0	Calm	N/A	overcast
	1230	0	Calm	N/A	overcast
	1330	0	Calm	N/A	overcast
	1400	0	Calm	N/A	cloudy
	1430	0	Calm	N/A	cloudy
	1500	0	Calm	N/A	cloudy
Stage 3					
24 Nov 04	0920	100	Southerly	10	overcast
	1000	100	Southerly	10	overcast
	1335	102	Southerly	10	overcast
	1400	102	Southerly	12	overcast
Stage 3					
13 Dec 04	1320	0	SW	3	cloudy
	1400	0	SW	3	cloudy
Stage 3					
14 Dec 04	1100	102	SSW	12 – 14	cloudy
	1145	102	SSW	12	cloudy
Stage 3					
15 Dec 04	1150	0	SSW	N/A	cloudy

IMPACT OF WIND TURBINE FARMS ON ATC RADAR – FURTHER ANALYSIS AND PROPOSED SOLUTIONS

FURTHER ANALYSIS

1. Introduction. The impact from wind turbines on radars can be categorised into 3 main forms: displayed clutter, obscuration and shadowing. All 3 effects were observed on the ATC Watchman Radar during this Trial. Technical solutions that have been proposed to either overcome, or mitigate against, these effects include: plot extractor/tracker processors, stealth modifications to wind turbines and increased reliance on SSR. Analysis of both the problems and the solutions are dependent on a degree of familiarity with ATC operations that is not available within the Air C2 OEU. Therefore, the ATC-specific contents of this Annex were checked for accuracy with a current RAF Senior ATC Officer, Watchman experts at DEI&IS and by reference to relevant support documentation produced by No 1 School of Technical Training, RAF Cosford.
2. Displayed Clutter. Clutter is probably the most significant effect of a wind turbine farm on any radar and may lie at the heart of all the other problems. Clutter affects radar in 2 fundamental ways. Firstly, when displayed to the operator it can mislead, inducing the operator to treat the clutter as though it were an aircraft. Secondly, the presence of clutter will effect the overall ambient noise level for the radar and raise the processing threshold in those clutter processing cells affected by the clutter.

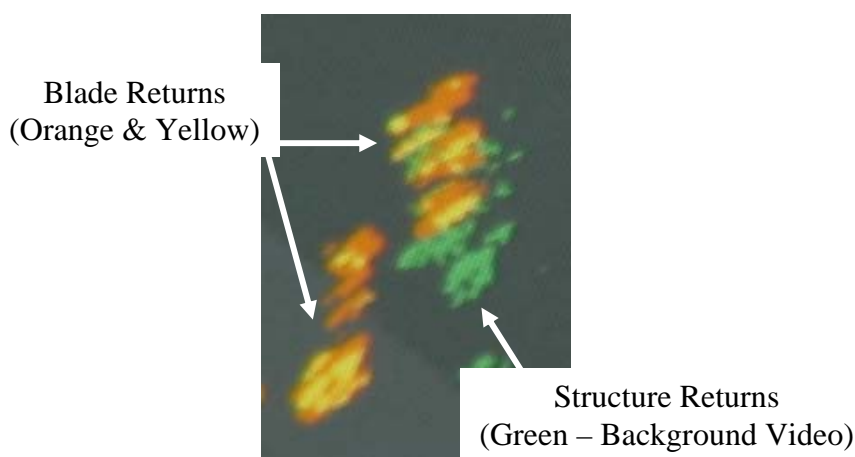

Figure 1 - Blade and Structure Returns from P&L Wind Turbine Farm.

In Figure 1, above, the yellow (current) and orange (history) returns from the motion of the blades are indistinguishable in appearance from aircraft returns. The green returns from the physical, static, structure are only displayed in background video and would not normally be selected for display by ATC operators. However, both blade returns and background video affect the ambient noise level and thus raise the processor threshold within the radar.

3. The returns from the turbine blades are processed for display for 2 key reasons. Firstly, even from a relatively small turbine such as the Mitsubishi Type 300 installed at the P&L wind farm, the RCS of the turbine blade flash can be as high as $315 - 1000^{21} \text{ m}^2$. This is considerably higher than a small jet aircraft like the Hawk T Mk 1A. Secondly, the tip speed of a typical onshore wind turbine is approximately 75 ms^{-1} ; the Watchman's MTI velocity gate can be as low as 10 ms^{-1} to enable detection of slow moving aircraft. Therefore, returns from a wind turbine blade pass both the thresholds and the MTI filter leaving them indistinguishable from real aircraft returns. Previous MoD ATC flight trials, conducted in 1994²², regarded displayed clutter from rotating wind turbines as a key issue and this was reinforced during this latest Trial. Displayed clutter is particularly pertinent for ATC. There are many occasions when it is highly undesirable for an aircraft receiving an ATS from an airfield to be obliged to manoeuvre around an unknown radar contact. This is particularly important when aircraft are operating in IMC and reliant on ATC for safe separation. In particular, aircraft should not routinely be obliged to take evasive actions in the following situations:

- a. PAR. Although a PAR service would generally only be applied to aircraft from approximately 15 nm range from the airfield it could be applied from 20 nm. In order to ensure that aircraft receiving a PAR service from ATC have at least 5 nm separation from false returns generated by wind turbines, development should be subject to scrutiny within 25 nm of the runway threshold. In line with the guidance in AP100G-03²³, this zone should extend 25° either side of the runway centreline, originating at the threshold. This restriction need only apply at airfields where PAR is or is likely to be installed.
- b. Surveillance Radar Approach (SRA). An SRA would generally be provided out to a range of 10-15 nm. In order to ensure that aircraft receiving an SRA from ATC have at least 5 nm separation from false returns generated by wind turbines, development should be subject to scrutiny within 20 nm of the threshold. In line with the tenor of the guidance offered in AP100G-03, this zone should extend 25° either side of the runway centreline, originating at the threshold.
- c. Radar Circuit. Aircraft operating IMC, or experiencing problems, will routinely operate in a radar circuit whilst they set-up for a PAR, SRA or other appropriate approach. During this procedure they are reliant on ATC for separation from other traffic. The radar circuit at an MoD airfield can require aircraft to operate at ranges up to 30 nm from the airfield, dependent on aircraft type and local procedures. It is highly undesirable for aircraft operating in such a pattern to routinely manoeuvre to avoid returns generated by turbines. As 30 nm represents an outer extreme for radar circuits at RAF airfields²⁴ we can omit the 5 nm buffer in this case. Therefore, wind turbine farm developments should be subject to scrutiny within 30 nm of a MOD airfield in order to support the safe conduct of radar circuits. The first 2 situations, PAR and SRA, lead to the following protected zones within which the construction of wind turbines is highly undesirable (assuming LoS):

²¹ 25-30 dBm².

²² RAFSEE Technical Report dated Dec 94 (*Study of the Effects of Wind Turbines on Radar Performance*).

²³ AP100G-03 Site Restrictions for Ground Radio Installations dated Oct 91.

²⁴ Most would be inside 20 nm.

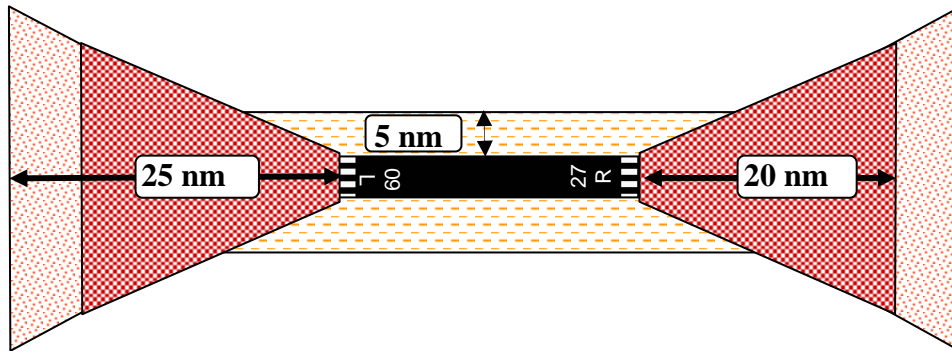

Figure 2 - Proposed Wind Turbine Development Protected Zone for MoD Airfields.
(supporting PAR and SRA)

However, in order to allow for safe conduct of radar circuits it is necessary to extend this zone to a circle of radius 30 nm, assuming LoS.

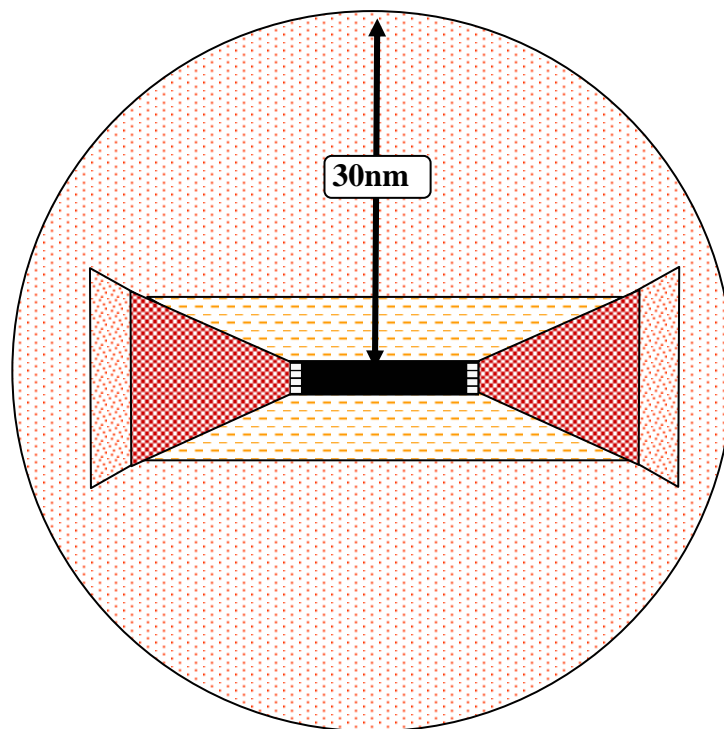

Figure 3 – Proposed Wind Turbine Development Protected Zone for MoD Airfields.
(supporting Radar Circuit, PAR and SRA)

4. Outside of the proposed protected zone at Figure 3, wind turbines remain of interest to ATC. Aircraft receiving an ATS will still be required to avoid returns generated by the blades of wind turbines. However, outside of the key SRA, PAR and Radar Circuit areas there would be more flexibility for aircraft to manoeuvre or for local procedures to take heed of permanent echoes such as those from wind turbines. Notwithstanding this enhanced flexibility, it would be undesirable for a wind turbine farm development of such magnitude that aircraft were unable to safely approach and depart a given airfield. Therefore, there is a need for an additional

'Restricted' zone within which the development of wind turbines should be subject to scrutiny by MoD. Interference from turbines will occur whenever a radar has LoS to a turbine. Restrictions on turbine developments were previously limited to 74 km (40 nm), representing the most common normal operating range for MoD airfield radars. However, MoD airfields operate variants of the Watchman Radar at ranges up to 80²⁵ nm²⁶. It is highly desirable for the MoD to operate a single, coherent, policy with regard to wind turbine farm developments. Therefore, wind turbine farm developments should be subject to scrutiny when within LoS of an MoD airfield radar regardless of range. Within the UK, it is likely that the vast majority of development sites would be beyond LoS before reaching 80 nm range. Due consideration should be given to routine traffic patterns for individual airfields, size of turbines²⁷, number of turbines and proximity of other wind turbine developments. Aircraft must be able to approach an airfield from beyond the limits of radar cover via a route which allows them to operate safely whilst retaining lateral separation of 5 nm on any wind turbine farm within radar coverage.

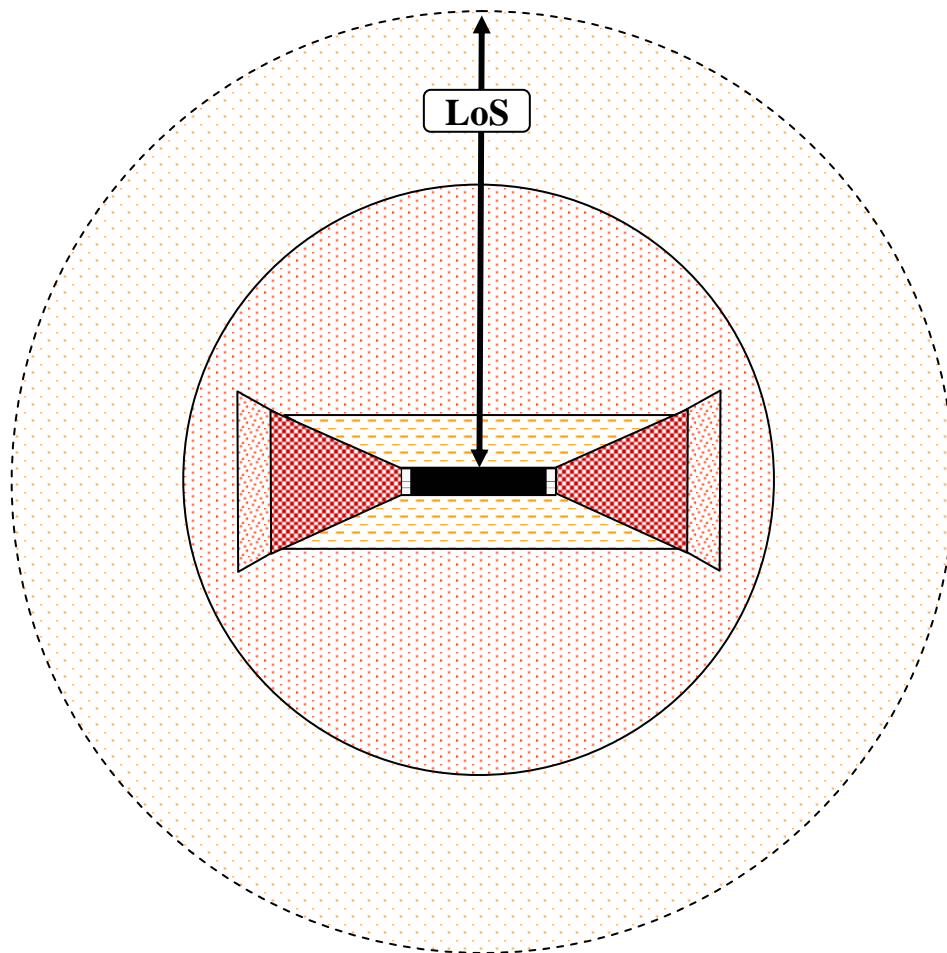

Figure 4 – Proposed Wind Turbine Development Restricted Zone for MoD Airfields.

²⁵ Watchman ER has a range of 120 nm.

²⁶ The introduction of low RCS into service may require more sensitive or higher power radars to maintain an ATS around military airfields.

²⁷ Particularly RCS.

5. Obscuration. As previously discussed, obscuration is a sub-set of clutter. For the purposes of this report the word obscuration refers specifically to conditions leading to loss of sensitivity in detection to such an extent that the aircraft returns are completely lost. Recent trials conducted by the Air C2 OEU against AD radars (3-D radars using passive Planar Phased Array antennae and multiple vertical beams) have indicated obscuration of aircraft when over-flying wind turbines. For AD radars this obscuration is believed to be a result of clutter processing techniques. A 2-D radar, such as the Watchman, is potentially more vulnerable to obscuration as it employs a single vertical beam (notwithstanding the relationship between the short-range auxiliary beam and the medium-range main beam). However, within that beam structure the clutter cells for the Watchman are considerably smaller than those of the Type 101 (T101) AD radar (60 m range and approx 1.4° azimuth for the Watchman).

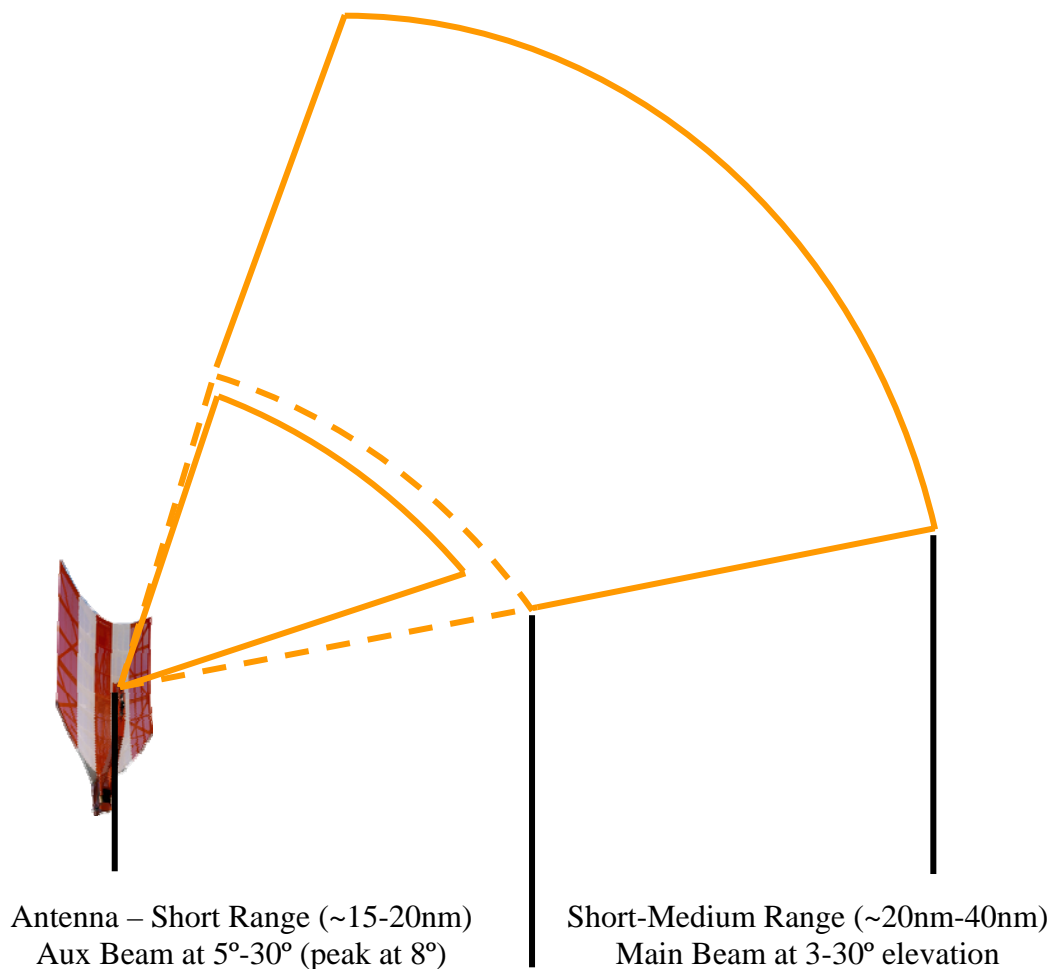

Figure 5 – Elevation View of Watchman Radar Beam Structure.

6. A detailed technical analysis of the clutter processing for the Watchman is beyond the scope of this report. Fundamentally, it is unlikely that conventional radar will extract aircraft returns from clutter when the amplitude of the aircraft return is significantly less than that of the clutter. Any averaging of clutter maps over several range cells will lead to impacts from wind turbines beyond the lateral boundaries of the wind turbine farm development. The differences between AD and ATC radars are not limited to beam structure and clutter cell size. Current

generation AD radars employ plot extraction and only provide the plot extracted picture to the aircraft controller. This technique is well proven but leaves the system potentially more vulnerable to background clutter. In a high clutter environment the plot extractor is unlikely to distinguish between low strength aircraft returns and high strength clutter returns. This is particularly pertinent in the example of a low RCS aircraft (such as the Hawk T Mk1A) flying over a high RCS clutter source (the wind turbine farm). During recent trials with AD Radar the incidence of dropped primary radar plots was considerably greater than for the same aircraft types operating over the same wind turbines during this ATC Radar Trial. However, during this Trial there were numerous occasions when a Watchman Operator was still able to distinguish between a reduced amplitude return from a real aircraft and the impermanent clutter returns from a wind turbine. It is likely that the automatic plot extractor on a T101 AD Radar struggled to match the sophistication of the human brain in this role. Therefore, whilst complete obscuration of the primary response was observed less often on the Watchman Radar than it had previously been on the T101 Radar this is likely to be a result of the different display methodologies (processed video on the Watchman v plot extraction on the T101).

7. Figure 6 shows how the wind turbine's structure, with no blades turning, can reduce the sensitivity of the radar by raising the ambient noise level. The exploded section, below right, shows a marked reduction in strength of return from a Dominie T Mk1A overflying the turbines.

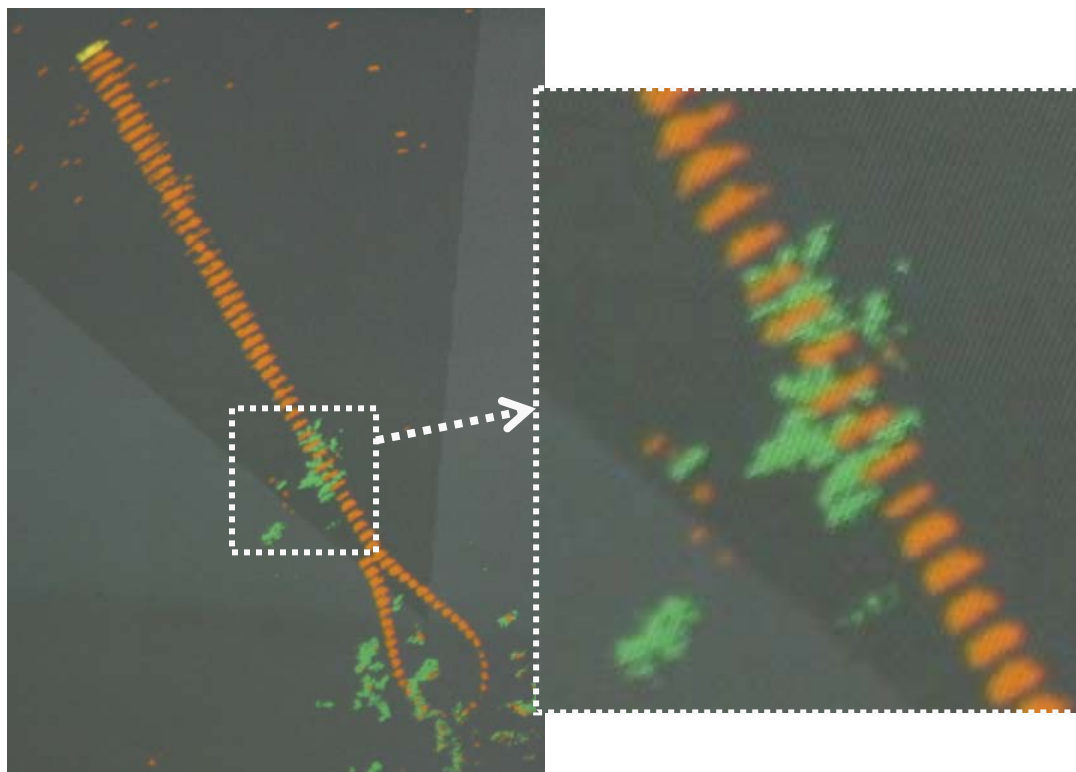

Figure 6 - Dominie at 4000 ft AMSL (all Channels Enabled) Overflying Turbines.

A controller can see that the returns in Figure 6 still belong to the same aircraft but there will be a level of signal reduction below which a plot extractor would fail to produce a plot even though the controller could still distinguish the return for his aircraft. The situation is more pronounced in Figure 7.

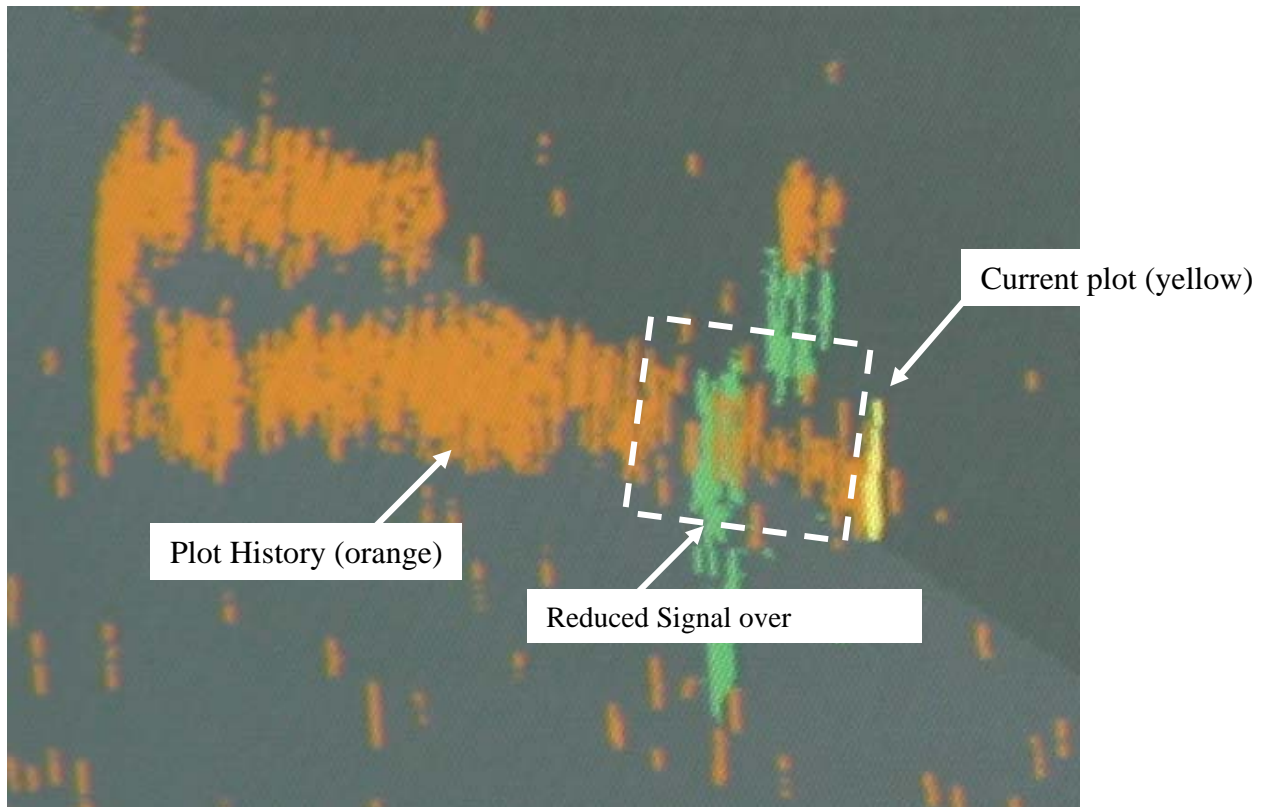

Figure 7 - Gazelle at 2000 ft AMSL with all Channels Enabled

Again, a controller can clearly follow the path of his aircraft but a plot extractor would probably drop multiple plots overhead the turbines, even though none were turning in this example. The problem of obscuration due to the ambient noise level being raised within the clutter cells was less pronounced for the Watchman Radar than it was for the plot extracted T101 AD Radar. It remains possible that a sufficiently intelligent plot extractor could outperform a human operator; this option is discussed under possible solutions below.

8. Shadow. The presence of a large physical obstruction in the path of the radar beam is known to result in a shadow region behind the object extending beyond the range within which diffraction would be expected to reform the beam. This is believed to be linked to how individual radar systems process clutter (both general background noise and false alarms). This was observed during this Trial but occurred both behind and in front of the turbines to a range of approximately 3 km and is shown at Figure 8.

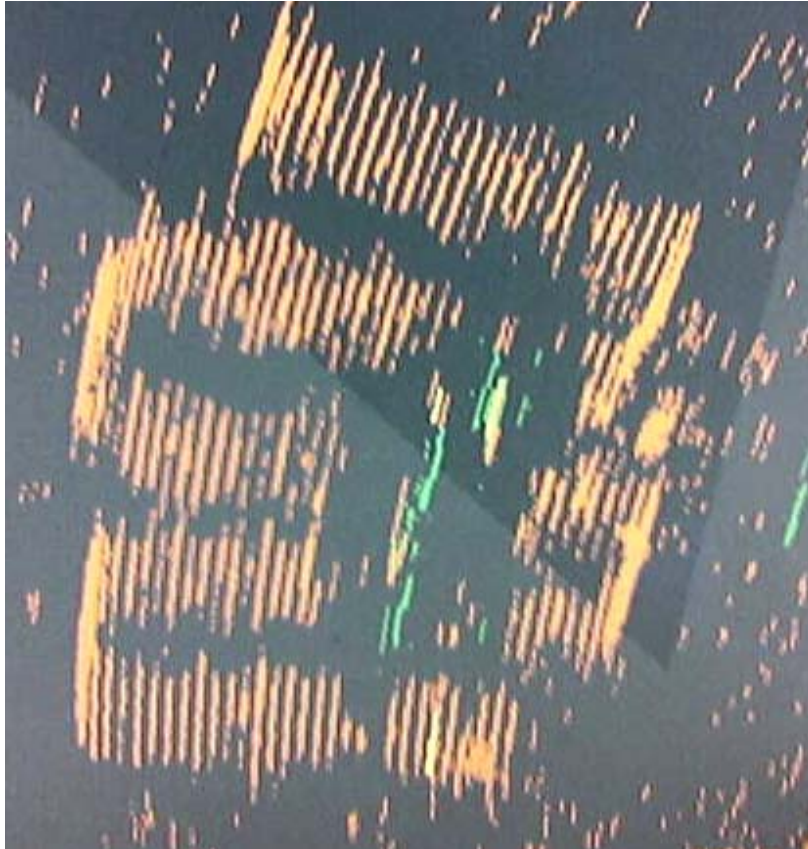

Figure 8 - Shadow Region Around P&L Wind Turbine Farm.

The loss of detection in front of the turbines, in relation to the radar, is not the result of conventional shadowing as would be experienced when an object blocks a light beam. There are several possible explanations for this effect but it is believed to result from the methods employed within the radar processing system to deal with clutter by raising the noise level in effected cells in the vicinity of the turbines. The basic compressed pulse length for the Watchman is $0.4 \mu\text{s}$, giving a 60 m range cell. Clutter in each range cell is assessed sweep by sweep and used to inform a clutter map using a process of alpha smoothing. This process does not explain the approximately 2-3 km shadow that was observed to either side of the wind turbines. The uncompressed pulse length for the Watchman is $20 \mu\text{s}$, giving a 3 km uncompressed range cell. For any radar system it is possible for many individual components within the processor to be driven into limit by sufficiently large returns. The exact signal strength required to achieve this is determined by many independent variables but the most significant considerations for the Watchman are whether the return is in the Auxiliary beam or the Main beam and the range from antenna to tgt. For these Trial deployment sites the received signal would have to be of the order of 40-50 dBi in order to drive the pre-compression circuitry into limit. Attenuation based measurements taken during the Trial suggest that the P&L wind farm has an RCS of approximately 315^{28} m^2 ; whilst these measurements are not precise it is assessed as highly unlikely that returns of the required amplitude (40-50 dBi) were being received during the Trial. Therefore, pre-compression limiting is not assessed as the cause of the observed shadow regions. No alternative technical explanation is available at this time.

²⁸ 25 dBm².

PROPOSED SOLUTIONS

9. There are several possible solutions to mitigate the effect of wind turbine farms. The main options are discussed below:

a. Plot Extraction. At the heart of proposals by both AMS and Sensis Corporation are systems that add plot extraction capabilities to the Watchman Radar. An evaluation of these proposals was not part of this Trial but the results that were obtained lend some credibility to the argument that a sufficiently advanced plot extractor could significantly mitigate the effect of a wind turbine farm on a Watchman Radar. The ATC community is concerned that the additional processing requirements of plot extraction may introduce an unacceptable level of latency. The implications of switching to plot extraction as the primary source of radar data for ATC should not be underestimated. It would be necessary to establish that performance had not been reduced in order to mask the displayed clutter from wind turbines. Plot extraction would need to be investigated thoroughly in a variety of environments.

b. SSR. The use of SSR is becoming increasingly prevalent within European airspace and this trend is expected to continue. Mode S and other proposed changes to the Eurocontrol SSR structure are expected to introduce more widespread regulation mandating SSR in the majority of European airspace. The Civil Aviation Authority has already considered proposals to make UK airspace a Mandatory Carriage of SSR Environment and this remains a strong possibility. Interference from wind turbines on SSR is possible but has not been observed during Air C2 OEU trials. Therefore, the impact of wind turbines on SSR is currently assessed as negligible. However, it remains undesirable to allow sizeable turbine developments in close proximity to SSR antennae until further investigation has been conducted to confirm the effect of wind turbine farms on SSR. In order for ATC personnel to be able to confidently ignore false primary returns from wind turbines they must be able to guarantee that all aircraft in their area of interest are transponding SSR. It is unlikely that the RAF will adopt complete reliance on SSR in the near future, nor will it be possible to guarantee that all aircraft operating in the vicinity of RAF airfields will be transponding SSR. In the short to medium term, SSR does not offer mitigation for the interference effects of wind turbines on MoD ATC radars. Primary radar is likely to remain an important asset for aircraft on approach in IMC even were en route traffic to be operating solely on SSR. Therefore, in the event that the UK were to adopt a Mandatory Carriage of SSR Environment as mitigation for the interference from wind turbines it is strongly recommended that the protected zone at Figure 2 remains.

c. Local Training. RAF airfields with an existing wind turbine farm interference problem have adopted local work-arounds to ensure that safety is not compromised. At RAF Valley, the location for Stage 1 of this Trial, this includes comprehensive training for local controllers to ensure that they are fully aware of the impact of the wind turbines on their picture. Training is only a valid mitigation for wind turbines where the developments are relatively small and avoid critical areas around the airfield. Therefore, local training would only be an appropriate mitigation for small wind turbine farms within the proposed Restricted Zone at Figure 4.

d. Stealth Technology. Several companies are actively pursuing research into reducing the RCS of both wind turbine blades and the static structure that supports them. Evidence to date suggests that achieving a level of RCS reduction is possible although as yet unproven in a fielded wind turbine system. The application of stealth, either scattering of reflections through the design of the structure or application of Radar Absorbent Materials is beyond the scope of this report. However, the RCS being predicted by modelling of the next generation of wind turbines proposed for offshore developments is of the order of 10 000 – 100 000²⁹ m². Current research would suggest a reduction of up to 20 dB by the application of stealth technologies, notwithstanding the complexities introduced by the effects of radar multipath reflection and of applying them correctly in a multi-turbine multi-sensor environment. Reducing the RCS of the proposed offshore turbines to 100 – 1000³⁰ m² would only lower them to the same order of magnitude as those used at the P&L wind turbine farm during this Trial. Therefore, it is unlikely that stealth technology will be able to offer a single solution to the problem of interference from large wind turbine farms. Stealth technology remains a feasible proposal for smaller installations but would require further analysis and demonstration of a fielded system before it can be regarded as a viable mitigation.

²⁹ 40-50 dBm².

³⁰ 20-30 dBm².

SORTIE PROFILES – STAGE 2

1. The profile for this Trial Stage 2 was a tangential and radial route, repeated at various heights. The trial area is shown below:

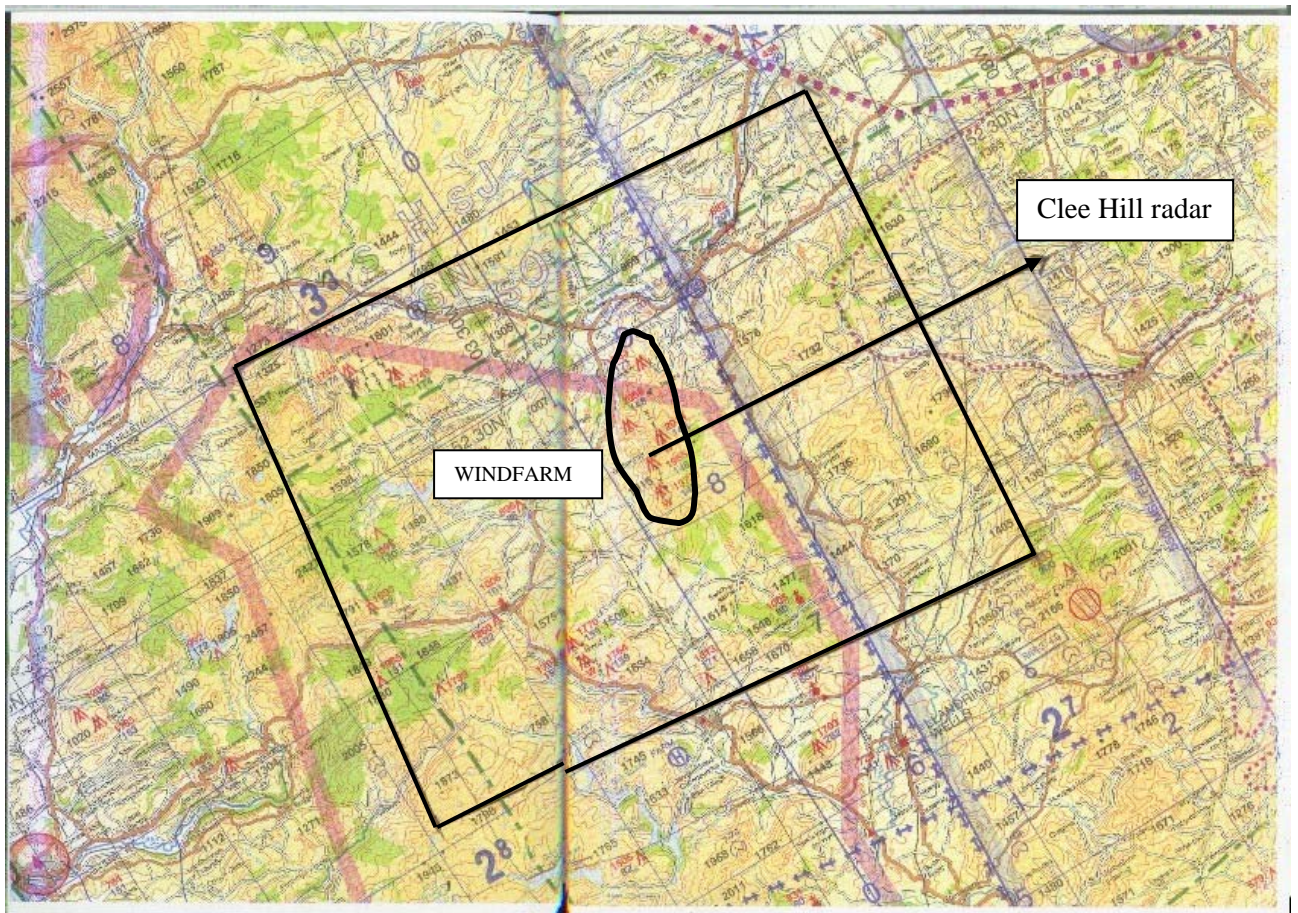

2. Profiles. The co-ordinates for the trial profiles are shown in the following diagrams:

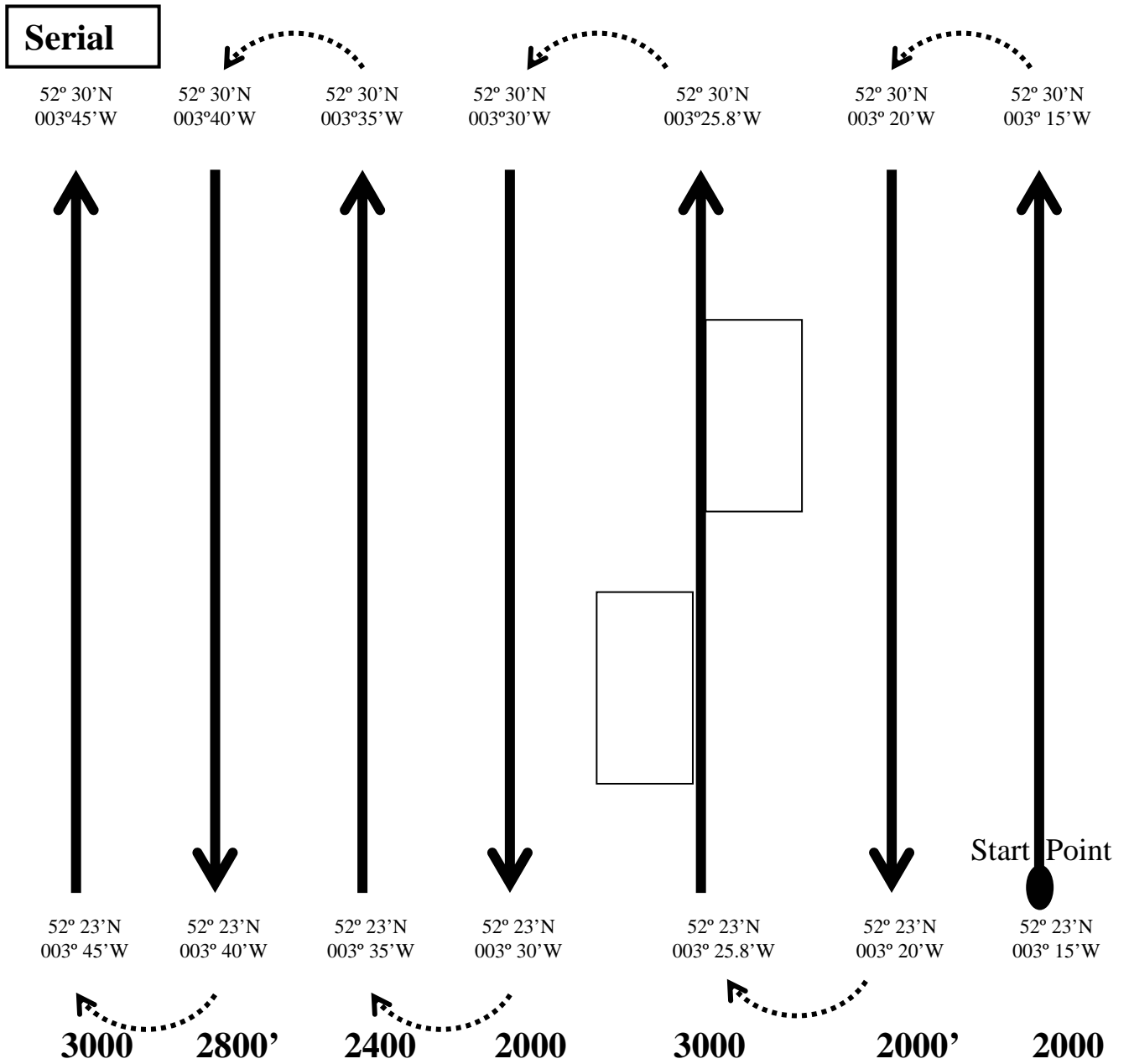

**All Heights: - AMSL, minimum desired height
(Pilot to use higher as required for safety of flight)**

Serial 2

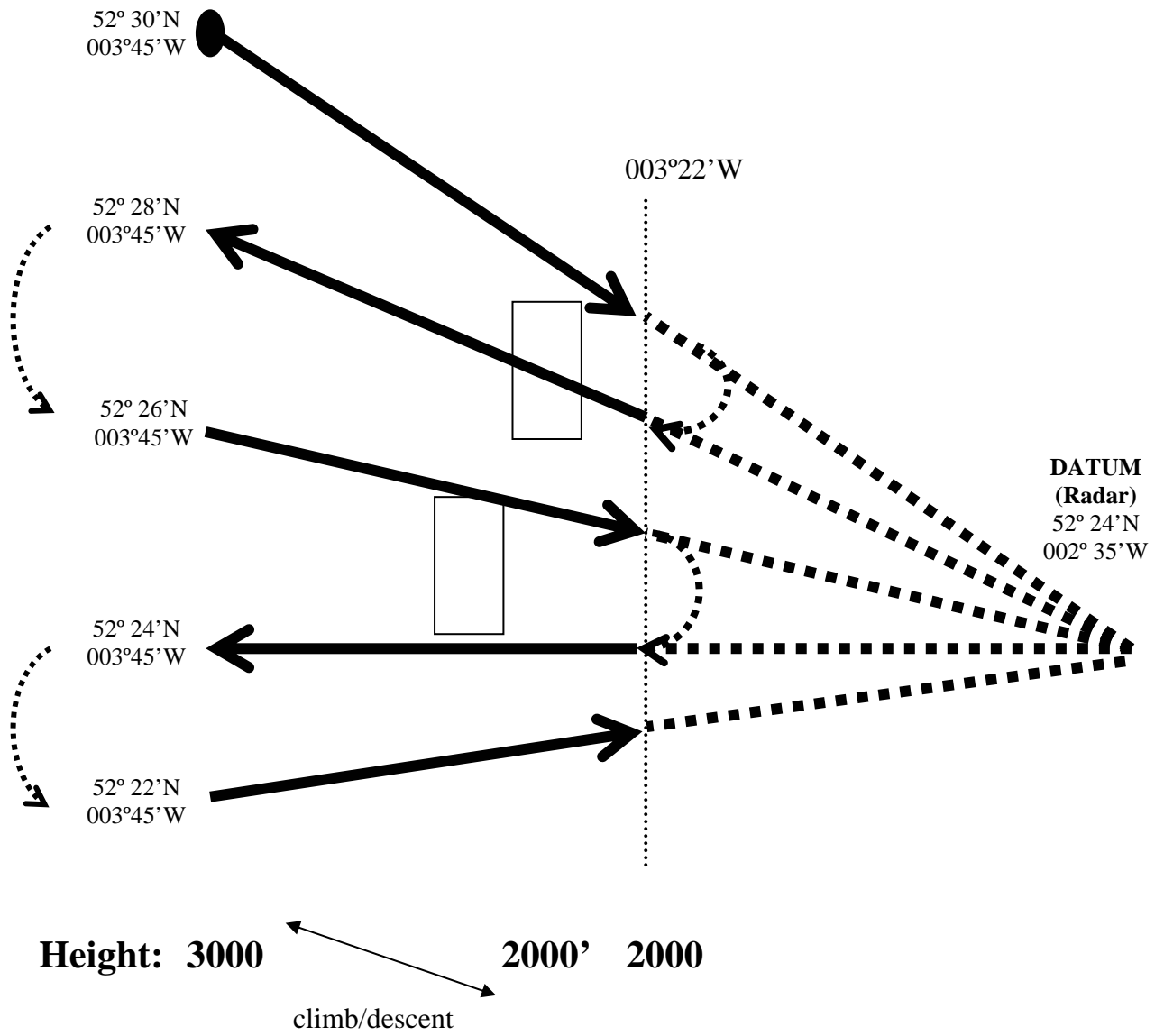

**All Heights: AMSL, minimum desired height
(Pilot to use higher as required for safety of flight)**

Serial 3 – Fuel / Time
dependent
– Flown if requested

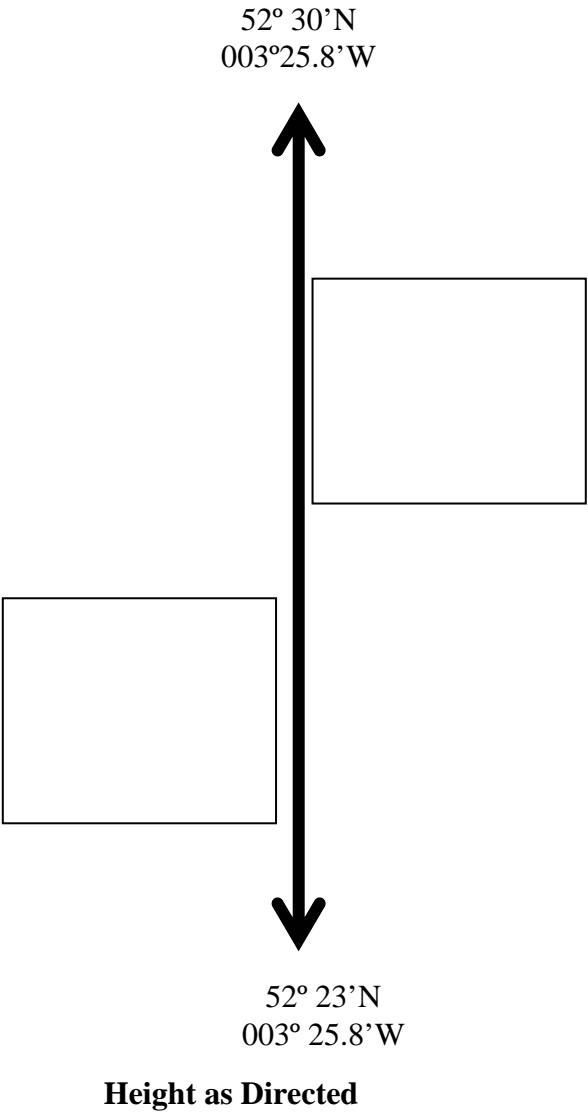

**All Heights: - AMSL, minimum desired height (higher as required for safety of flight)
- climb only in turn**

SORTIE PROFILES – STAGE 3

1. Introduction. The profiles for this Trial were a combination of tangential and radial legs, relative to the radar, followed by legs along the line of the subject wind turbine farm. Aircraft ground speeds were approximately 200 kts unless higher speeds were required to comply with specific aircraft safety requirements. The speed for the Gazelle AH1 was dictated by capability and prevailing conditions.

2. Trial Profiles. The co-ordinates for the Trial profiles are as follows:

Serial 1

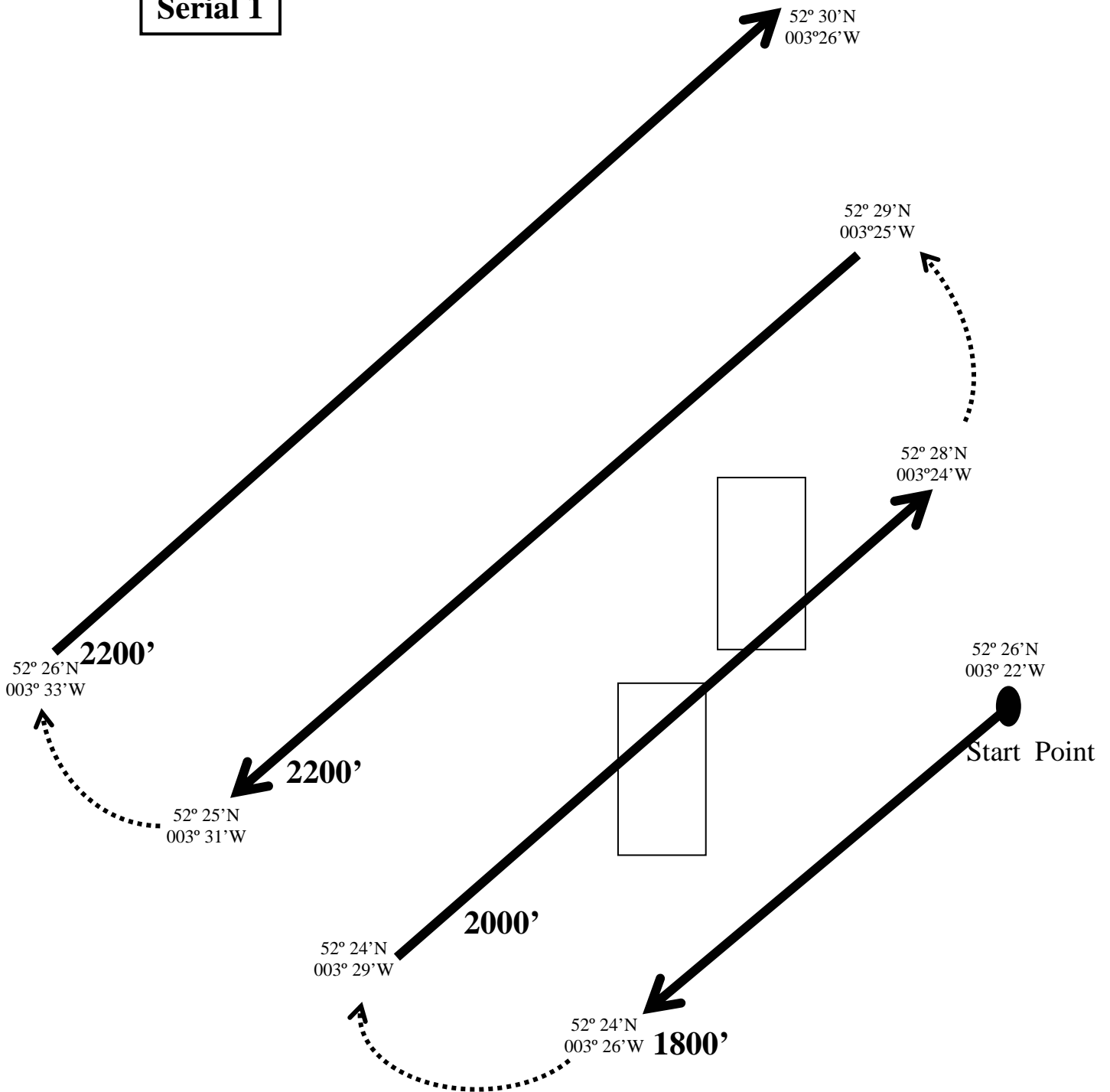

**All Heights: - AMSL, minimum desired height
(Pilot to use higher as required for safety of flight)
- climb only in turn**

Serial One LOW – Heights as above (VMC dependent)

Serial One HIGH – Heights as directed

Serial 3 – Fuel / Time dependent
– Flown if requested
– Heights as directed

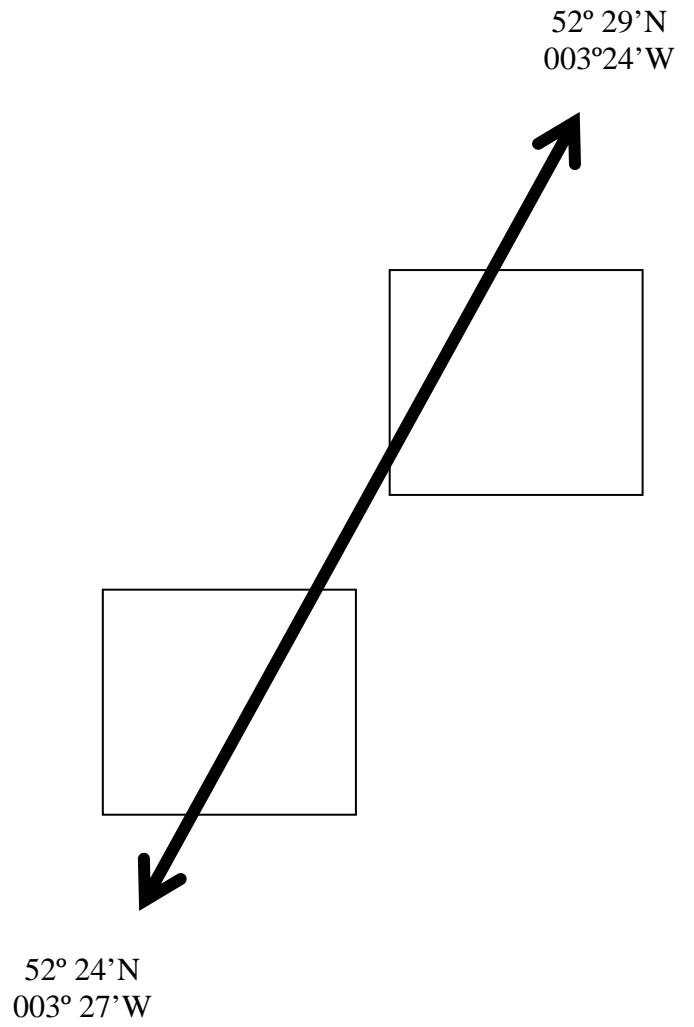

Height as

**All Heights: - AMSL, minimum desired height (higher as required for safety of flight)
- climb only in turn**

WATCHMAN DISPLAY OUTPUT DURING STAGE 2

1. Introduction. This Annex contains Watchman Radar display output captured during playback of the data recorded during Stage 2 of this Trial.
2. Background Video. Figure 1 shows background video from the Watchman Radar during the Trial. At the point of data capture, no turbine blades were in motion. The effects observed result solely from the static structures of the wind turbine development. At close ranges, there is a preponderance of background clutter from terrain, this is less common at longer range. The background video display is unable to distinguish the magnitude of different returns but separate attenuation measurements indicated that the wind turbine masts were presenting noise to the antenna at approximately 25 dBi above ambient noise level at a range of 57 km. This figure would increase significantly for larger turbines unless stealth technology was incorporated to reduce the effective RCS.

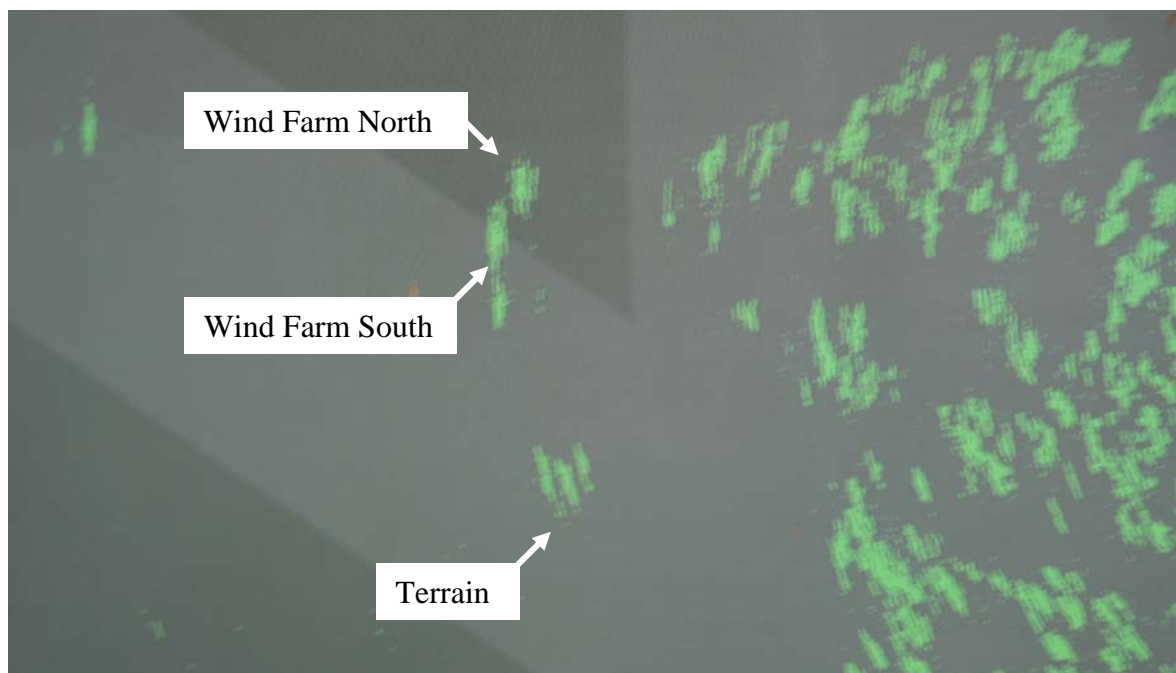

Figure 1 - Background Video.

3. Channel 1 (MTI) Only – Dominie. Figure 2 shows the radar display for a Dominie T Mk1A travelling north toward the wind turbines at 1800 ft AMSL. The radar is displaying Channel 1 (Normal Radar) only.

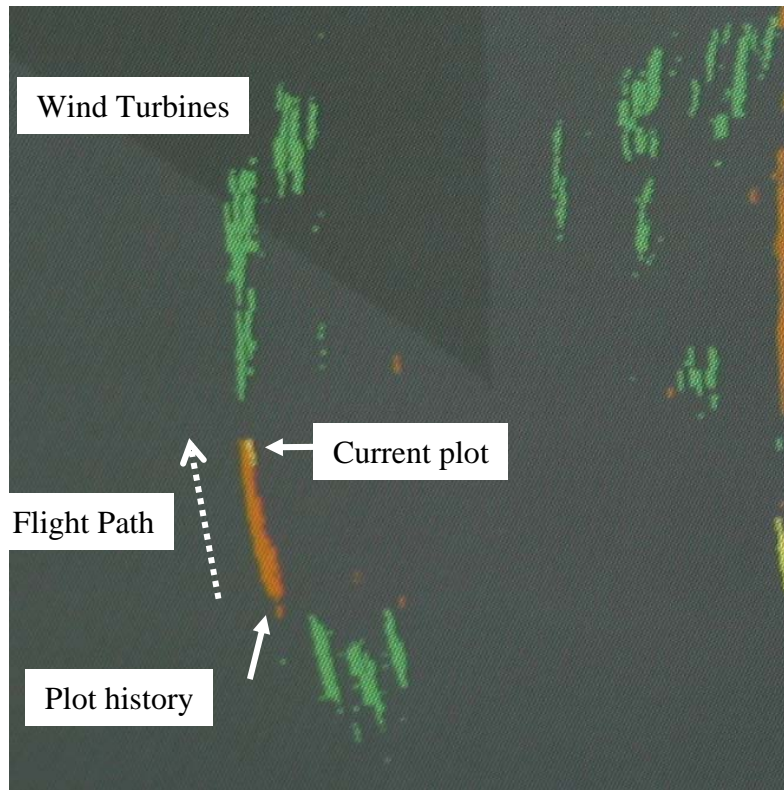

Figure 2 - Dominie Northbound at 1800 ft - MTI Radar Only.

4. In Figure 3, plot information on the Dominie aircraft was lost as it overflowed the wind turbines; only the plot history remains. In such situations the plot did not reappear until the aircraft cleared the far side of the wind turbines.

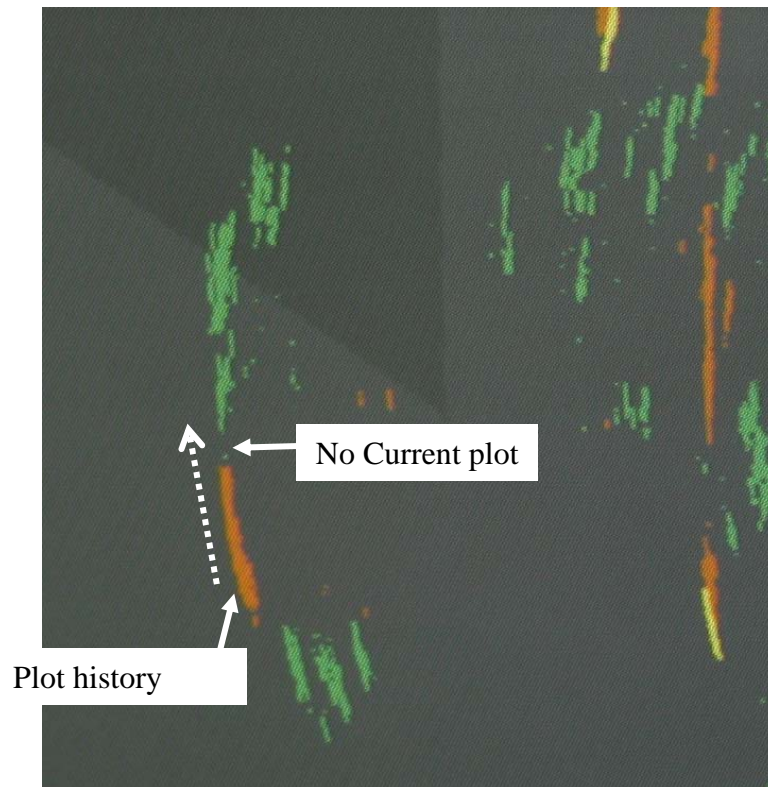

Figure 3 - Dominie Northbound at 1800 ft - MTI Radar Only.

This is reinforced at Figure 4, showing the permanent history of an aircraft as it overflowed the same wind turbine farm, again with only Channel 1 displayed:

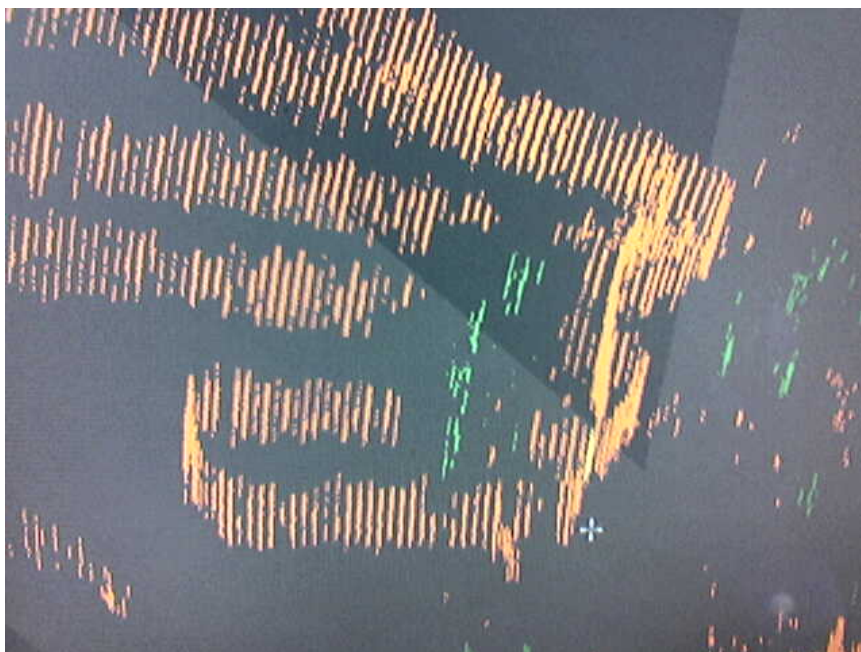

Figure 4 - Permanent History of aircraft overflying P&L Windfarm - MTI Radar Only

5. All Radar Channels (Standard Operating Procedures for ATC) – Gazelle 2000 ft. The Watchman Radar is designed to operate with all 3 channels enabled (Normal (MTI), Ground Clutter Filter, Moving Clutter Filter). However, filtering of individual channels remains at the discretion of the user and can provide a valid tool for optimisation of the picture. Figures 2-4 show how badly wind turbines affected the Normal channel, whether or not the blades were turning. By contrast, Figure 5 shows a Gazelle flying over the wind turbine farm with no turbines turning but all channels selected for display. The reduction in effective signal strength was easily discernible to the eye but was considerably less than the impact with only Normal channel data displayed. Primary radar returns were lost for 2 or 3 sweeps at the start of the overflight and were considerably weakened until the aircraft had completely cleared the turbines.

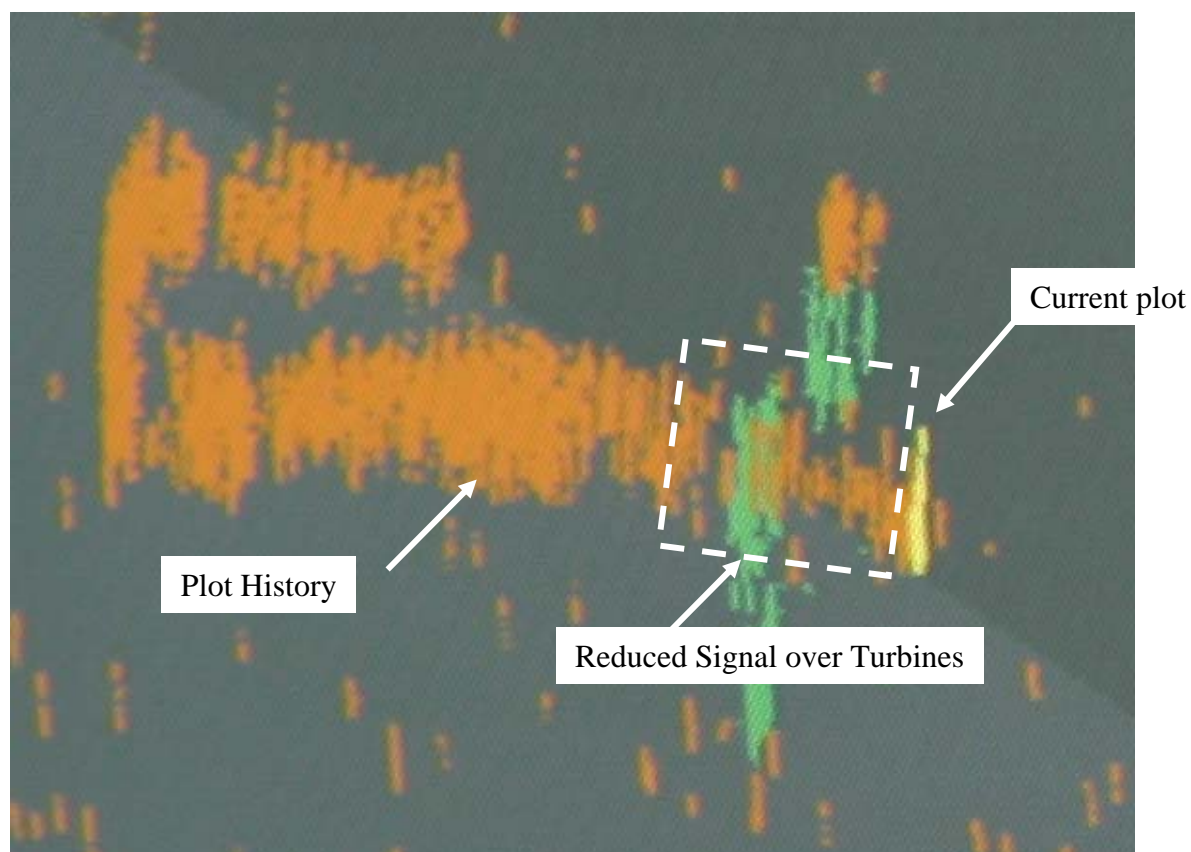

Figure 5 - Gazelle at 2000 ft AMSL with all Channels Enabled.

6. All Radar Channels – Hawk 2000 ft. The effect on primary radar returns observed for the Gazelle, at Figure 5, was repeated for the Hawk, shown at Figure 6. Once again, the reduction in signal strength was clearly visible on the display screen. Primary returns were lost intermittently throughout the particular flight profile shown below. However, the reduction in strength and complete loss of primary returns overhead the wind farm was a consistently observed effect.

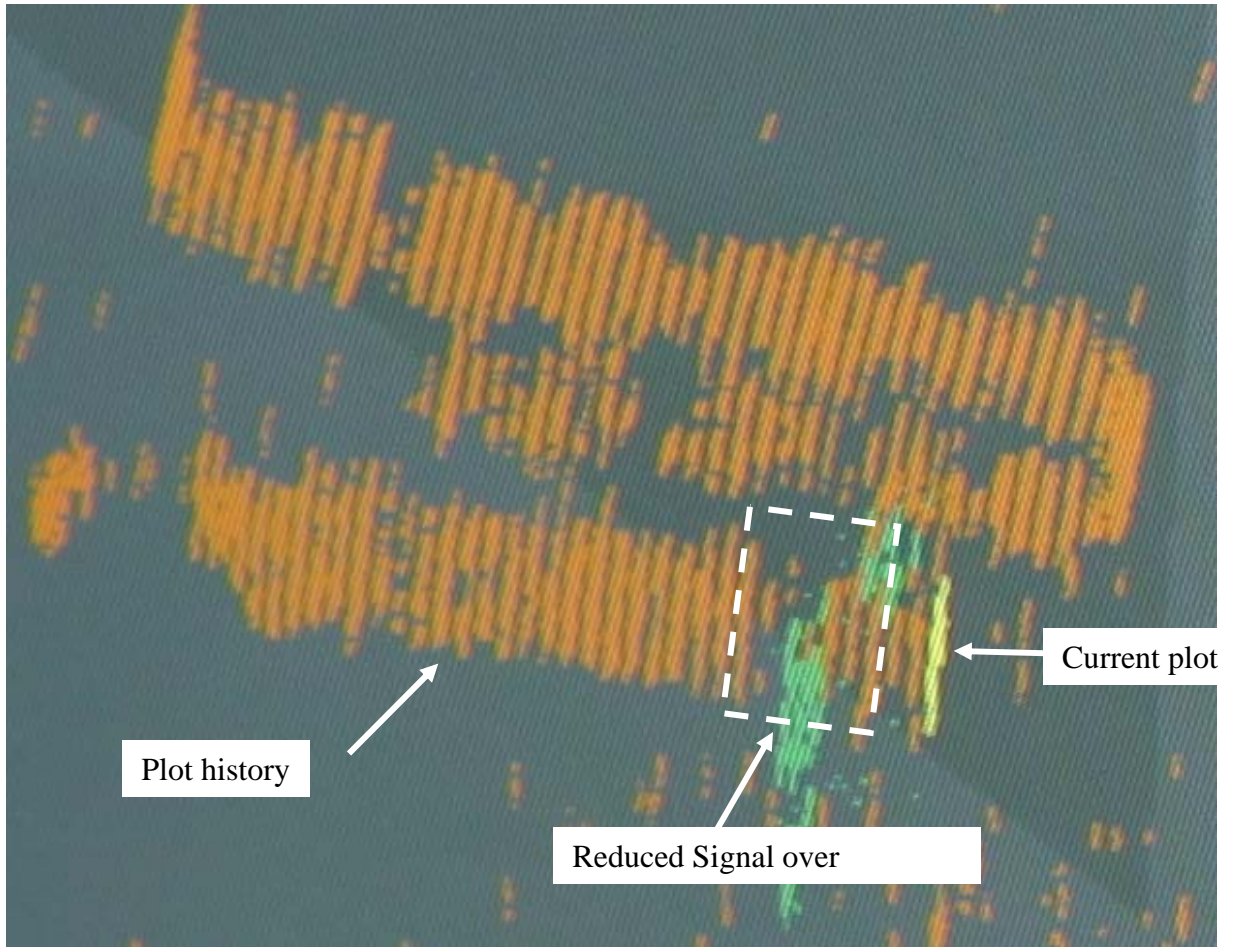

Figure 6 - Hawk at 2000 ft AMSL with all Channels Enabled.

7. All Radar Channels – Hawk 6000 ft. Figure 7 shows the effect on primary radar detection for a Hawk T Mk1A aircraft flying North to South over the wind turbines on an approximate tangent to the radar. That portion of the overflight where primary returns were completely lost is expanded at Figure 8.

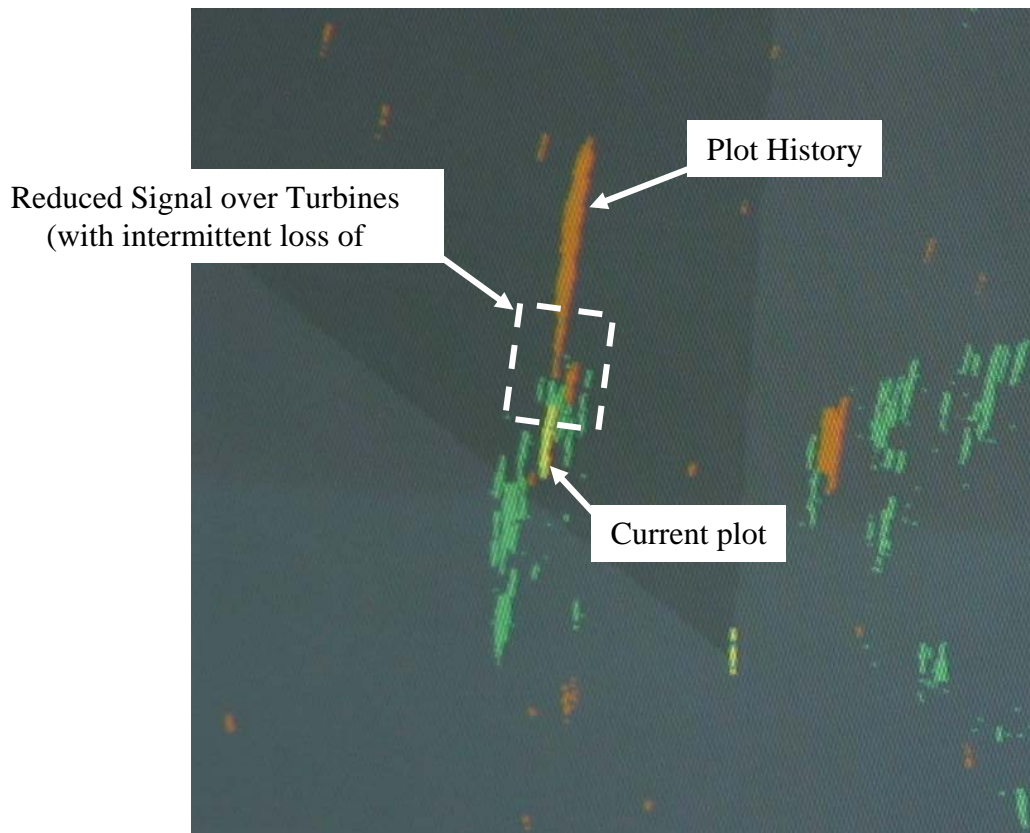

Figure 7 - Hawk at 6000 ft AMSL with all Channels Enabled.

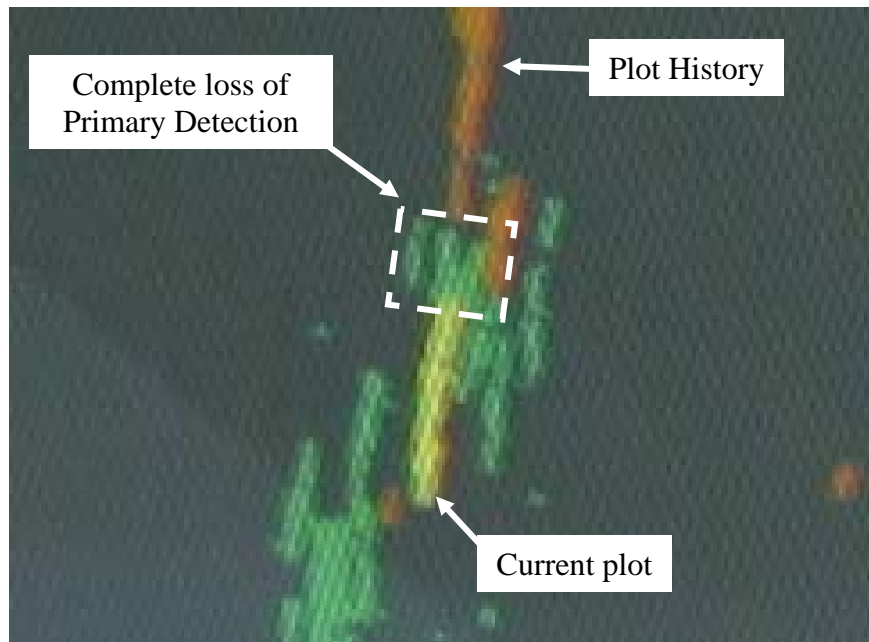

Figure 8 - Expanded view of Hawk at 6000 ft AMSL (as above).

8. All Radar Channels – Tucano 5000 ft. The radar display in the vicinity of the turbines was significantly different when they were turning rather than static. At Figure 9, 2 aircraft can clearly be distinguished as conventional plots with history. In the centre of the screen, the returns from the wind turbines in motion are equally distinct. At Figure 10 the radar display when an aircraft overflew the wind turbines whilst they were in motion is shown. It was impossible to distinguish the precise location of an aircraft overflying the turbines or even determine to any certainty whether an aircraft was present. For this reason, ATC personnel are obliged to treat primary returns from the turbines as though they were real aircraft.

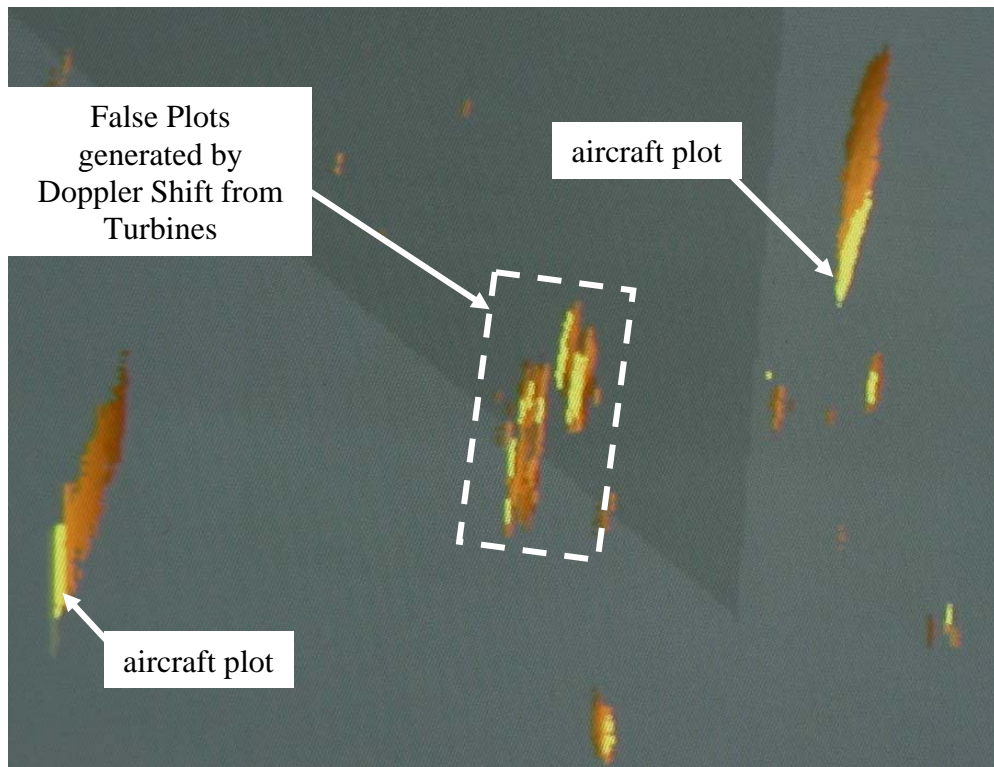

Figure 9 - Hawk at 6000 ft AMSL with all Channels Enabled.



Figure 10 - Expanded View of Turbines in Motion with Coincident Aircraft Returns.

WATCHMAN DISPLAY OUTPUT DURING STAGE 3

1. Introduction. The basic observations made during Stage 3 of this Trial were broadly the same as those made during Stage 2.
2. All Radar Channels – Hawk 2000 ft. Figures 1a and b show a Hawk T Mk 1A approaching and overflying the wind turbines. The aircraft is flying a tangential profile relative to the radar.

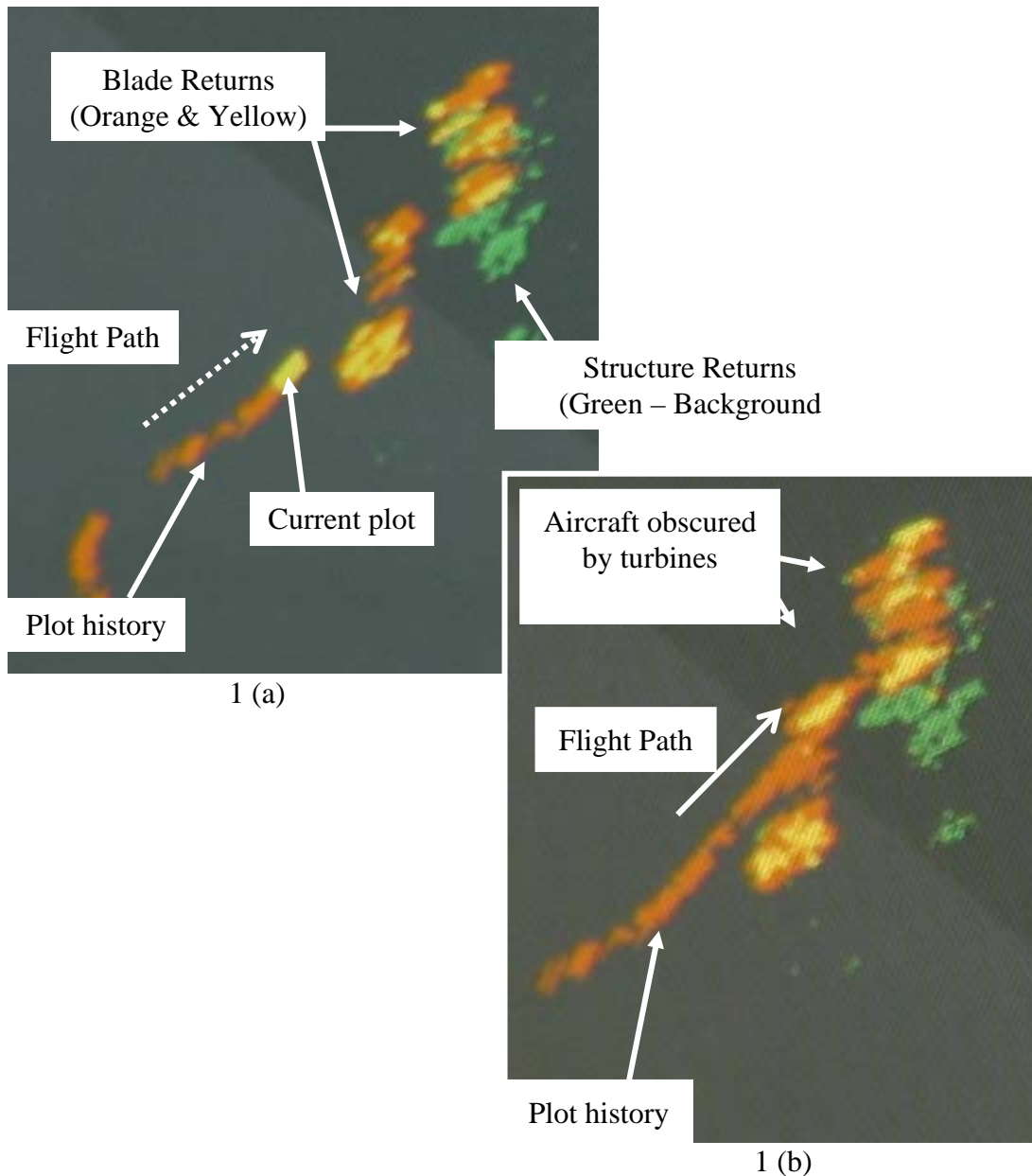

Figure 1 - Hawk at 2000 ft AMSL (all Channels): Approaching (1 (a)) and Overflying (1 (b)) Turbines

On its approach to the wind turbine farm the aircraft plot was distinct and easily identified. However, it was not possible to distinguish the responses resulting from the Doppler Shift induced by the rotating turbine blades from those of an aircraft by any means other than prior knowledge. Figure 1b demonstrates how completely the wind turbine responses mask those of the Hawk T Mk1A, as they would for any other aircraft. This has a double deleterious effect. The controller can no longer identify his own aircraft and the controller cannot identify whether any other aircraft are in conflict with those receiving an ATS. Either of these effects is sufficient to oblige a controller to treat the wind turbines as though they were an unknown aircraft in conflict and avoid them laterally.

3. All Radar Channels – Dominie 4000 ft. Figure 2 shows the radar trace of a Dominie T Mk1A overflying the P&L wind turbine farm. All radar channels were enabled but no turbines were turning. For Stage 3 the radar was positioned such that the turbines were within the coverage of the Auxiliary beam, introducing a vertical tilt component³¹. The expanded view, below right, shows very little degradation in the Dominie's primary returns in this instance.

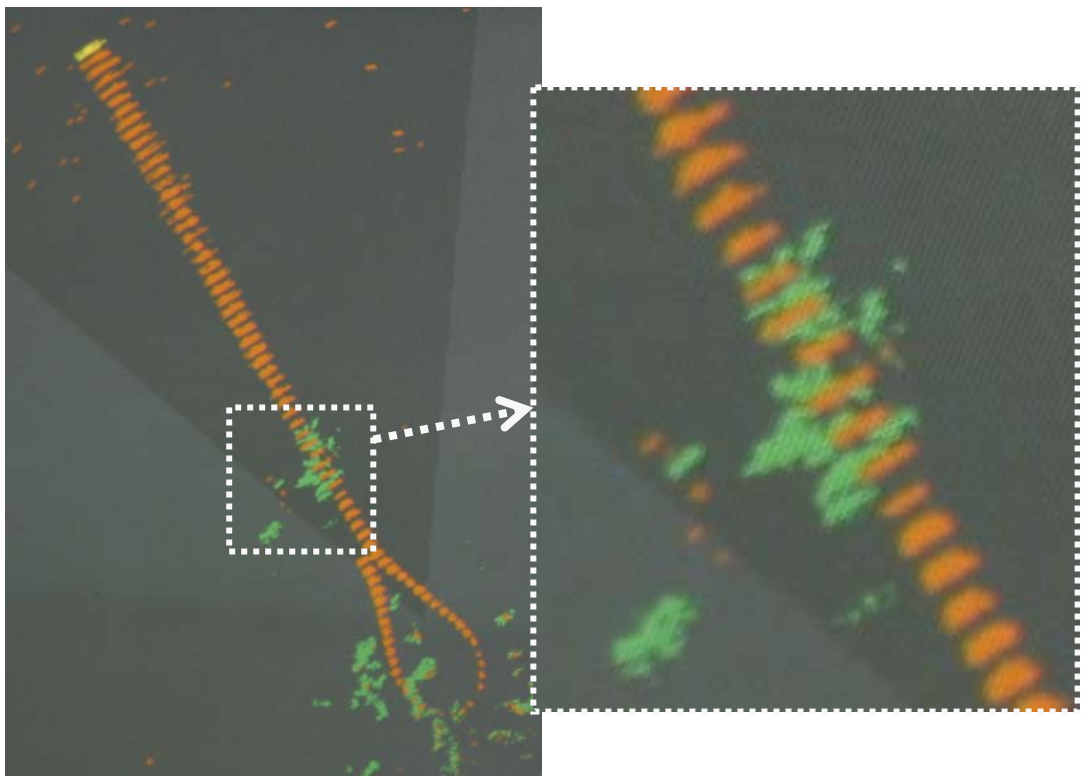

Figure 2 - Dominie at 4000 ft AMSL (all Channels Enabled) Overflying Turbines.

³¹ The auxiliary beam is tilted on receive to look over ground clutter close to the antenna.